



User manual

Contents

Before use

Manuals for This Product.	4
Downloading the Latest Version.	4
Symbols Used in This Guide.	5
About Models of this Product.	6
How to Identify the Model by the Model Number.	6
How the Models are Described in this Manual. . .	6
Auto Cutter Model.	6
Peeler Model.	8
Gloss Black Ink/Matte Black Ink (CW-C6000/C6500 Series).	9
Product and Driver Versions.	10
How to Check the Product Version.	10
How to Check the Printer Driver Version.	10
Screens in This Manual.	11
Product Illustrations.	11
Safety Precautions.	12
Cautions on Installation.	12
Cautions on Handling.	12
Cautions on Power Supply.	13
Cautions on Ink Cartridges.	15
Cautions on the Maintenance Box.	17
Caution Label.	18
Supported paper.	19
Paper Shape/Form/Size.	19
Paper Type.	22
Paper That Cannot Be Used.	23
Part Names and Functions.	24
Front.	24
Rear.	25
Inside.	26
Spindle and Flange.	27
Operation Panel.	28

Basic Operation

Turning On or Off.	30
Turning the Power On.	30
Turning the Power Off.	30
Opening the Paper Cover.	31
Opening the Cover using the Lever in the Front. .	31
Opening the Cover using the Lever in the Back. .	31
Checking the Printer Status.	32
Checking the Paper Information.	32
Checking the Status of Consumables.	33

Printing Nozzle Check Patterns.	33
Printing Status Sheet.	34
Checking Network Connection and Settings. . . .	34
Replacing the Ink Cartridges.	35
Checking Amount of Ink Remaining.	35
How to Replace the Ink Cartridges.	35
Replacing the Maintenance Box.	38
Checking the Amount of Empty Space in the Maintenance Box.	38
How to Replace the Maintenance Box.	38
Printer Driver Settings.	41
Media Definition.	42
Media Name.	42
Label width.	42
Label Length.	42
Gap between labels.	43
Left & Right gap.	43
Media Form.	43
Media Saving.	43
Media Coating Type.	44
Print Quality.	44
Color Correction.	45
Spot Color Setting.	45
Settings For Paper Handling After Print.	46
Notification.	46
Pause.	47
Media Detection.	47
Loading and Replacing Paper.	48
How to Load Paper (Auto Cutter Model - Supply from Inside).	50
How to Load Paper (Auto Cutter Model - Supply from Outside).	55
How to Load Paper (Peeler Model - Supply from Inside).	60
How to Remove Paper (For the Auto Cutter Model).	67
How to Remove Paper (For the Peeler Model). . .	69
How to Eject Paper at Paper End (For the Auto Cutter Model).	71
How to Eject Paper at Paper End (For the Peeler Model).	72

Maintenance

Cleaning the Exterior.	74
Cleaning the Auto Cutter (Auto Cutter Model Only).	75
Cleaning the Peeler (Peeler Model Only).	77

Contents

Cleaning the Edge Guides.	78
Cleaning the Platen.	79
Cleaning the Paper Feed Roller.	80
Cleaning the Paper Pressure Roller.	82
Cleaning the Print Head.	84
Printing Nozzle Check Patterns.	84
Head Cleaning.	85

Troubleshooting

A Message is Displayed on the Operation Panel. . .	86
Problems with Print Quality.	90
Horizontal White Banding.	90
Vertical White Spots (Auto Cutter Model).	90
White or Black Banding.	90
Printed Colors Are Wrong.	90
Print Position Shifts.	91
Paper is Smearred or Smudged with Ink.	91
Paper is Fed and Ejected, and an Error Occurs. . .	91
Printing is Impossible or Becomes Suddenly Impossible.	92
Print Data is Sent, But Does Not Print (Peeler Model).	92
Printing from a computer is impossible or becomes suddenly impossible.	92
Checking Whether the Printer Driver Is Installed.	92
The printer does not turn on.	92
Print Job is Canceled on PC but “Printing” Message on Printer Does Not Disappear.	92
Paper is jammed.	94
For the Auto Cutter Model.	94
For the Peeler Model.	97

Specifications

CW-C6000 Series.	100
Product Specifications.	100
Electrical Specifications.	101
Overall Dimensions.	101
CW-C6500 Series.	102
Product Specifications.	102
Electrical Specifications.	103
Overall Dimensions.	103
CW-D6000 Series.	104
Product Specifications.	104
Electrical Specifications.	105
Overall Dimensions.	105
CW-D6500 Series.	106

Product Specifications.	106
Electrical Specifications.	107
Overall Dimensions.	107
Environmental Specifications.	108
Paper Specifications.	109
CW-C6000/C6500 Series.	109
CW-D6000/D6500 Series.	109
Ink Cartridge.	110
Maintenance Box.	111





Appendix

Consumables and Options.	112
Ink Cartridge.	112
Maintenance Box.	113
Roll Paper Holder.	114
Restriction of Use.	115
Notes.	116
Trademarks.	116

Before use

This chapter describes information you should know before using the product.

Manuals for This Product

<p>Paper manual</p> 	<p>Start Here Guides you through basic setup steps from unpacking to loading paper.</p>
<p>Manual viewable with PC</p> 	<p>User's Guide (This Manual) Describes details about the functions and operating procedures of the product, maintenance information, and troubleshooting.</p>
<p>Manual viewable with PC</p> 	<p>CW-C6000 Series/CW-C6500 Series Technical Reference Guide CW-D6000 Series/CW-D6500 Series Technical Reference Guide Provides information necessary for installing the product, performing daily tasks, and developing a system using the product. This document can be found at the following URL. <https://epson.sn></p>
<p>Manual viewable with PC</p> 	<p>Online Video Manual Provides videos that show you operating procedures and troubleshooting information. The videos can be found at the following URL.</p> <ul style="list-style-type: none"> ❑ CW-C6000/C6500 Series: <https://support.epson.net/p_doc/790/> ❑ CW-D6000/D6500 Series: <https://support.epson.net/p_doc/ab6/> <p>The contents of videos are subject to change without notice.</p>

Downloading the Latest Version

The latest versions of the printer driver, utilities, and manuals can be downloaded from the following URL.

For customers in North America, go to the following web site:

<<https://www.epson.com/support/>>

For customers in other countries and regions, go to the following web site:



<<https://epson.sn>>

Symbols Used in This Guide



The following symbols are used in this guide to indicate important information.

Symbols for Safety

The symbols shown below are used in this manual in order to ensure safety and proper use of this product and to prevent danger to you and other persons, and property damage. Be sure that you completely understand their meanings before reading this manual.

 Warning	Handling the product improperly by ignoring this symbol can lead to death or serious injury.
 Caution	Handling the product improperly by ignoring this symbol can lead to injury and property damage.

Symbols for General Information

 Important	Indicates information with which you must comply when using the product. Mishandling due to ignoring this information may cause the product to fail or malfunction.
Note	Indicates supplementary explanations and information you should know.
	Indicates a reference page containing related information.

About Models of this Product

This manual is for the CW-C6000 Series, CW-C6500 Series, CW-D6000 Series*, and CW-D6500 Series*.

You can check which model your printer is by the model number on the front of the printer.

* May not be available in some countries or regions.

How to Identify the Model by the Model Number

CW-C6000Au
(1) (2) (3)

- (1) The pigment ink model is "C" and the dye ink model is "D".
- (2) The 4-inch model is "0" and the 8-inch model is "5".
- (3) The auto cut model is "A" and the peeler model is "P".

How the Models are Described in this Manual

In this manual, information specific to one or more particular models is presented as follows.

- Example 1) When the information is common to both CW-C6000 Series and CW-C6500 Series
Gloss Black Ink/Matte Black Ink (CW-C6000/C6500 Series)
- Example 2) When the information applies only to the auto cutter model
Gloss Black Ink/Matte Black Ink (Auto cutter model only)

Auto Cutter Model

- Features

Equipped with an auto cutter. The paper can be cut either according to the application settings, or with the help of the **Cut** button on the operation panel.

- Ink Types

Compatible ink types vary depending on the printer model number.

- CW-C Series: Uses pigment ink and supports two types of black ink.  [“Gloss Black Ink/Matte Black Ink \(CW-C6000/C6500 Series\)” on page 9](#)
- CW-D Series: Uses dye ink and supports one type of black ink.

- Model number

Before use

Model number	Model numbers used in the manuals	Ink Types	Remarks
ColorWorks D6500Pe	CW-D6500Pe	dye ink	8-inch model

Gloss Black Ink/Matte Black Ink (CW-C6000/C6500 Series)

You can select which type of black ink to use from gloss black (BK) and matte black (MK). The printer prompts you to select it when you turn on the printer for the first time.

Supported paper types vary by the black ink type. See [“Paper Specifications” on page 109](#).

 Important	You cannot change the black ink type once you select the black ink type and let the printer charge the ink.
--	---

Product and Driver Versions

Use the product with a combination of latest versions of the product firmware, printer driver, and utility.

Note	For users of CW-C6000/C6500 Series If the firmware version is one of the following versions, download the latest version of the firmware and update the printer using the latest one. TS05JC, TS06JC, TS26JC, TS19K2, TS25K3, TS21K5 🔗 “Downloading the Latest Version” on page 4
-------------	---

How to Check the Product Version

You can check the version of your product firmware by printing the status sheet. Check the results of status sheet printing. [🔗 “Printing Status Sheet” on page 34](#)

You can also check the version on the operation panel.

Menu - Printer Status/Print - Firmware Version

How to Check the Printer Driver Version

You can check the version in the printer driver screen.

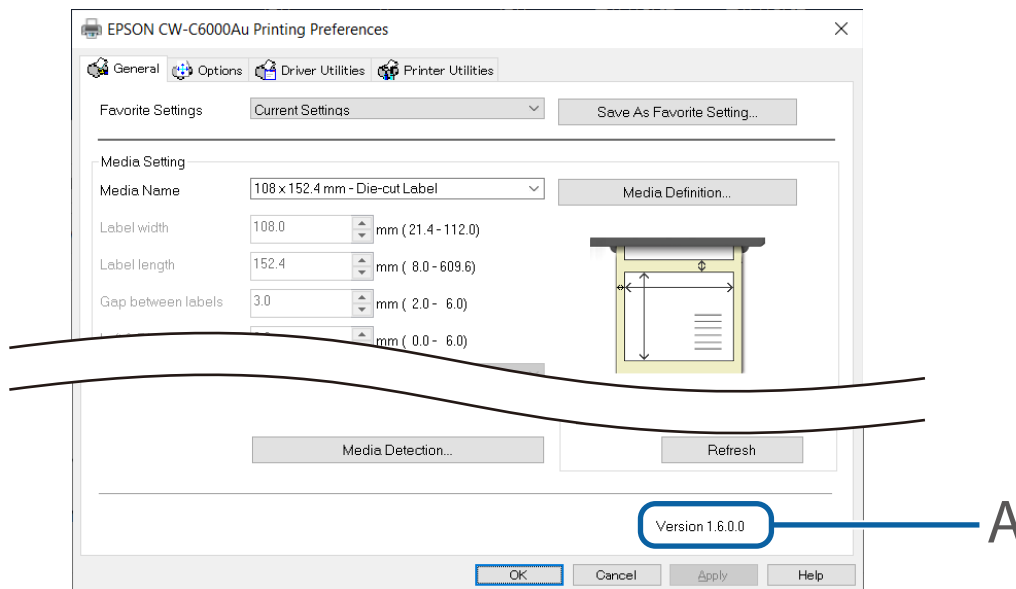

A: Printer driver version

Screens in This Manual

The screens in this manual and the screens actually displayed in Windows may differ depending on the product used and operating system. Unless otherwise specified, the screens in this manual are those when using Windows 10.

Product Illustrations

The product illustrations used throughout this manual may slightly differ from the product you are using. Unless otherwise stated, illustrations of CW-C6000Au are used.

Safety Precautions

To ensure safe use of the product, be sure to read this manual and the other instruction manuals supplied with the product before use. Store this manual in a safe place so that you can resolve any unclear points regarding the product at any time.

Cautions on Installation

Warning

Do not block the air vents of the product.

Doing so can result in heat accumulated in the product causing a fire. Do not cover the product with a cloth or install it in a poorly-ventilated location. Furthermore, ensure there is the installation space specified in the manual.

 [“Rear” on page 25](#)

Caution

- Do not install/store the product in an unstable location or in a location subject to vibration from other devices. Equipment may fall or collapse, causing breakage and possible injury.
- Do not install the product in a location exposed to oily smoke or dust, or in a humid location. Doing so may cause electric shock or fire.
- When lifting the product, perform the work with the correct posture. Lifting the product with an inappropriate posture may cause injury.
- Because the product is heavy, do not attempt to carry the product by one person. When unpacking or moving the product, make sure to carry the product by at least two persons. For information on the weight of this product, see below.

 [“Specifications” on page 100](#)

- Do not install this product at a location exposed to strong light such as direct sun rays. Doing so may cause the detector to malfunction and the printer may not print properly.

Cautions on Handling

Warning

- Do not use the product in a location with volatile substances such as alcohol or paint thinner present, or near fire. Doing so may cause electric shock or fire.
- Shut down the product immediately if it produces smoke, a strange odor, or unusual noise. Doing so may cause electric shock or fire. If an abnormality occurs, immediately turn off the power and remove the plug from the outlet, and then contact qualified service personnel for advice.

Before use

- ❑ Shut down the product immediately if a foreign object or water or other liquid gets inside the product. Doing so may cause electric shock or fire. Immediately turn off the power and remove the plug from the outlet, and then contact qualified service personnel for advice.
- ❑ Do not disassemble the areas other than those mentioned in this manual.
- ❑ Never repair the product yourself as doing so is dangerous.
- ❑ Do not use the product in a location where inflammable gas, explosive gas, etc. is present in the atmosphere. Furthermore, do not use aerosol sprayers containing flammable gas inside or around the product. Doing so may cause fire.
- ❑ Do not connect cables in ways other than those mentioned in this manual. Doing so may cause fire. It may also damage the other connected devices.
- ❑ Do not touch the areas inside the product other than those mentioned in this manual. Doing so may cause electric shock or burns.
- ❑ Do not insert metal or flammable materials, or allow them to fall into the product. Doing so may cause electric shock or fire.
- ❑ If the screen of the printer is damaged, handle the liquid crystal inside it very carefully. Should any of the following situations arise, take emergency measures.
 - ❑ When any part gets onto your skin, wipe off the deposit, and wash the area properly with soap and water.
 - ❑ When any part gets into your eyes, flush them with clean water for at least 15 minutes, and thereafter, consult with a doctor.
 - ❑ When a part gets into your mouth, immediately consult with a doctor.

Caution

- ❑ Do not allow anyone to stand or place heavy objects on top of the product. In particular, be careful in the case of a household with children. Equipment may fall or collapse, causing breakage and possible injury.
- ❑ Install the cables and optional products in the proper direction according to the proper procedures. Doing so may cause fire or injury. Follow the instructions in this manual to install them properly.
- ❑ Before moving the product, shut down and unplug the product, and make sure that all the cables are disconnected. Failure to do so may damage a cable, causing electric shock or fire.
- ❑ Do not store or transport the product while it is tilted, standing, or upside down. Doing so may cause the ink to leak.
- ❑ Do not use the printer with the paper cover removed. Doing so will cause the printer to malfunction.

Cautions on Power Supply

Warning

Before use

- Do not allow dust or other foreign material to adhere to the power plug. Doing so may cause electric shock or fire.
- Do not use a power cord other than that supplied with the product. In addition, do not use the supplied power cord with another device. Doing so may cause electric shock or fire.
- Do not use a damaged power cord. Doing so may cause electric shock or fire. Contact qualified service personnel for advice if the power cord is damaged. Furthermore, observe the following points so as not to damage the power cord.
 - Do not modify the power cord.
 - Do not place heavy objects on the power cord.
 - Do not forcibly bend, twist, or pull the power cord.
 - Do not lay the power cord near a heating appliance.
- Do not insert or remove the power plug with a wet hand. Doing so may cause electric shock.
- Do not connect many power cords to one outlet. Doing so may cause fire. Supply power directly from a power outlet.
- Regularly disconnect the power plug from the outlet and clean the base of the prongs and between the prongs. Leaving the power plug connected to the outlet for a long period of time may cause dust to accumulate on the base of the power plug prongs, resulting in a short and fire.
- Hold the plug and do not pull the cord when disconnecting the power plug from the outlet. Pulling the cord may damage the cord or deform the plug, causing electric shock or fire.





To ensure safety, unplug the product before leaving it unused for an extended period.

Cautions on Ink Cartridges





Caution

- ❑ The ink cartridges that can be used differ depending on the model number of the product. Use ink cartridges suitable for the model number of your printer.

 [“Ink Cartridge” on page 110](#)
- ❑ Do not touch the IC chip on an ink cartridge. Doing so may result in normal operation and printing becoming no longer possible.
- ❑ The product uses ink cartridges equipped with IC chips to manage the amount of ink used and other information so ink cartridges are usable even if they are removed and reinstalled. However, if an ink cartridge with not much ink remaining is removed and reinstalled, it may not be usable. Some ink is consumed each time cartridges are installed because the product automatically checks their reliability.
- ❑ When replacing the black ink cartridge, make sure to replace with a cartridge of the same type of black ink. The printer does not work if you install a cartridge of different type of black ink. (CW-C6000/C6500 Series)
- ❑ Install ink cartridges of all colors. Printing is not possible if even only one ink cartridge is missing.
- ❑ Since ink cartridges are designed to stop the operation before ink runs out completely to maintain the quality of the print head, some ink remains in the used ink cartridges.
- ❑ All the ink colors are consumed also for the maintenance operations when an ink cartridge is replaced and for print head cleaning.
- ❑ Do not turn off the power or open the ink cartridge cover during ink charging (while the  (power) LED lamp is flashing). Opening the cover may cause the ink to be recharged, resulting in more ink being consumed. Also, it may result in normal printing becoming no longer possible.
- ❑ Even for monochrome printing, all the ink colors are used in an operation designed to maintain the printing and print head quality.
- ❑ Do not disassemble an ink cartridge. Doing so may cause ink to get into eyes or onto skin.
- ❑ Do not disassemble or modify an ink cartridge. Doing so may cause printing malfunction.
- ❑ Use of old ink cartridges may result in reduced print quality. Use ink cartridges up within six months after opening the packages. The usage period for ink cartridges is printed on the packaging of the individual ink cartridges.
- ❑ If ink contacts your skin, eyes, or mouth, take the following actions.
 - ❑ When ink gets onto your skin, immediately wash the area with soap and water.
 - ❑ When ink gets into your eyes, immediately flush them with water. Leaving the ink as is may result in bloodshot eyes or mild inflammation. If something is wrong, immediately consult with a doctor.
 - ❑ When ink gets into your mouth, immediately spit it out and consult with a doctor.
- ❑ There may be some ink around the ink supply port on a removed ink cartridge. Take care so that it does not stain the desk or other surface.

Before use

- ❑ Do not open an ink cartridge package until you are ready to install the ink cartridge in the product.
- ❑ Do not shake an ink cartridge too hard. The ink cartridge may leak if you shake it around too much or push the sides strongly.
- ❑ Do not allow foreign objects to fall into the cartridge installation section. Doing so may result in normal printing becoming no longer possible. Remove any object that falls into the installation section, taking care not to damage the section.
- ❑ When ink is charged the first time (right after purchase), ink is consumed for filling the print head nozzles (ink discharge holes) to get ready for printing. Therefore, the number of the sheets that can be printed may be fewer than for cartridges installed later.
- ❑ When the printer is powered off with the  (power) button, the print head is automatically capped to prevent the ink from drying. When you will not use the printer after installing the ink cartridges, be sure to turn the power off with the  (power) button. Do not pull out the power plug or turn off the breaker while the power is on.
- ❑ Printing on water-repellent paper such as art paper, which is slow-drying, may cause print stains. Also, if you print on glossy paper, fingerprints may get on the paper or ink may adhere to your fingers when you touch the print surface. Select and use paper that will not cause print stains.
- ❑ Store the ink cartridges in a place out of reach of children.
- ❑ Epson recommends storing ink cartridges in a cool and dark place.
- ❑ If you wish to use ink cartridges that have been stored in a cold place for a long period of time, leave them for at least 3 hours in a place that is at room temperature before use.
- ❑ Do not remove the ink cartridges from the product when storing or transporting the product.

Cautions on the Maintenance Box





- Store in a place out of reach of children. Do not drink any adhered ink.
- Do not disassemble or modify the maintenance box. Doing so may cause ink to get into eyes or onto skin.
- Do not touch the IC chip on the maintenance box.
- If a maintenance box that can still be used has been removed and left detached for a long period of time, do not reuse it.
- Do not peel off the film from the top surface of the maintenance box.
- If ink contacts your skin, eyes, or mouth, take the following actions.
 - When ink gets onto your skin, immediately wash the area with soap and water.
 - When ink gets into your eyes, immediately flush them with water. Leaving the ink as is may result in bloodshot eyes or mild inflammation. If something is wrong, immediately consult with a doctor.
 - When ink gets into your mouth, immediately spit it out and consult with a doctor.
- Do not shake a used maintenance box too hard. The ink may leak from the maintenance box if you swing or shake it too hard.
- Avoid storing the maintenance box under high temperatures or in a frozen state.
- Keep it away from direct sunlight.

Before use

Caution Label

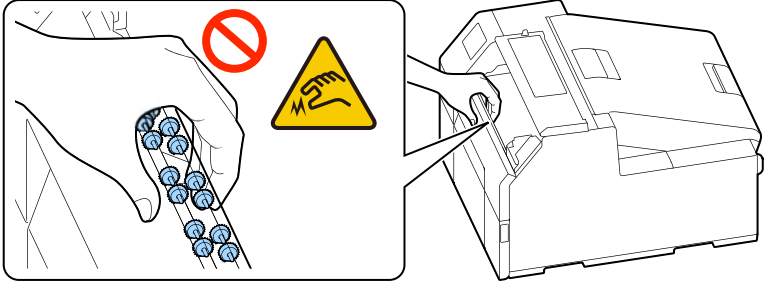
The labels affixed to the product indicate the following cautions.

 Warning	<p>Do not touch the roller at the bottom of the paper holder unit with your hand. Doing so may cause injury.</p> 
--	---

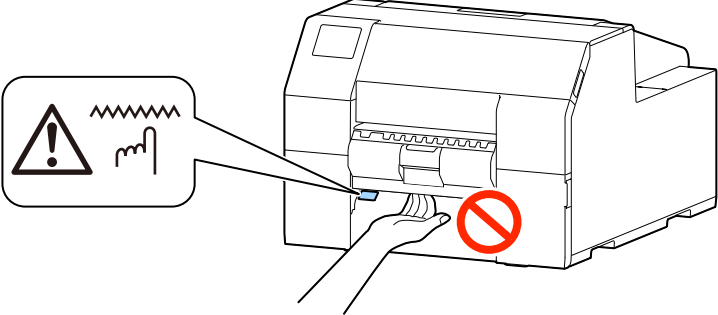







 Caution	<p>Do not touch the manual cutter at the bottom of the peeler cover with your hand. Doing so may cause injury.</p> 
---	--

Supported paper

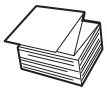

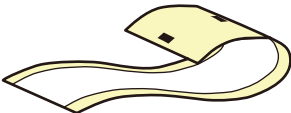



This section describes about shape, form, size and type of paper that can be used by this printer, and paper that cannot be used. For more details, see the *Technical Reference Guide*.

Paper Shape/Form/Size

CW-C6000/D6000 Series

Forms of paper	Paper Shapes	Paper width (mm {inch})	Backing paper width (mm {inch})	Label width (mm {inch})	Gap between Labels (mm {inch})
Continuous paper without adhesive (With black marks*1) 	Roll paper 	25.4 to 112 {1.00 to 4.41}	---	---	---
Continuous paper without adhesive (With black marks*1) 	Fanfold paper 	25.4 to 112 {1.00 to 4.41}	---	---	---
Continuous paper without adhesive (Without black marks) 	Roll paper 	25.4 to 112 {1.00 to 4.41}	---	---	---
Full-page label (With black marks*1) 	Roll paper 	---	25.4 to 112 {1.00 to 4.41}	Without waste parts: 21.4 to 108 {0.84 to 4.25} With waste parts: 25.4 to 108 {1.00 to 4.25}	---
Full-page label (Without black marks) 	Roll paper 	---	25.4 to 112 {1.00 to 4.41}	Without waste parts: 21.4 to 108 {0.84 to 4.25} With waste parts: 25.4 to 108 {1.00 to 4.25}	---







Before use

Forms of paper	Paper Shapes	Paper width (mm {inch})	Backing paper width (mm {inch})	Label width (mm {inch})	Gap between Labels (mm {inch})
Die-cut label (With black marks*1) 	Roll paper 	---	25.4 to 112 {1.00 to 4.41}	21.4 to 108 {0.84 to 4.25}	2.0 to 6.0 {0.08 to 0.24}
Die-cut label (With black marks*1) 	Fanfold paper 	---	25.4 to 112 {1.00 to 4.41}	21.4 to 108 {0.84 to 4.25}	2.0 to 6.0 {0.08 to 0.24}
Die-cut label (Gap*2) 	Roll paper 	---	25.4 to 112 {1.00 to 4.41}	21.4 to 108 {0.84 to 4.25}	2.0 to 6.0 {0.08 to 0.24}









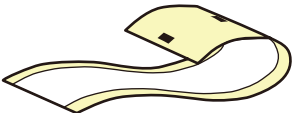

*1: The print position is detected based on the black marks printed on the back of the paper.

*2: The print position is detected based on the gaps between labels.

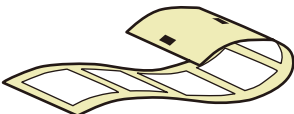
CW-C6500/D6500 Series

Forms of paper	Paper Shapes	Paper width (mm {inch})	Backing paper width (mm {inch})	Label width (mm {inch})	Gap between Labels (mm {inch})
Continuous paper without adhesive (With black marks*1) 	Roll paper 	25.4 to 215.9 {1.00 to 8.50}	---	---	---
Continuous paper without adhesive (With black marks*1) 	Fanfold paper 	25.4 to 215.9 {1.00 to 8.50}	---	---	---
Continuous paper without adhesive (Without black marks) 	Roll paper 	25.4 to 215.9 {1.00 to 8.50}	---	---	---

Before use

Forms of paper	Paper Shapes	Paper width (mm {inch})	Backing paper width (mm {inch})	Label width (mm {inch})	Gap between Labels (mm {inch})
Full-page label (With black marks* ¹) 	Roll paper 	---	25.4 to 215.9 {1.00 to 8.50}	Without waste parts: 21.4 to 211.9 {0.84 to 8.34} With waste parts: 25.4 to 215.9 {1.00 to 8.50}	---
Full-page label (Without black marks) 	Roll paper 	---	25.4 to 215.9 {1.00 to 8.50}	Without waste parts: 21.4 to 211.9 {0.84 to 8.34} With waste parts: 25.4 to 215.9 {1.00 to 8.50}	---
Die-cut label (With black marks* ¹) 	Roll paper 	---	25.4 to 215.9 {1.00 to 8.50}	21.4 to 211.9 {0.84 to 8.34}	2.0 to 6.0 {0.08 to 0.24}
Die-cut label (With black marks* ¹) 	Fanfold paper 	---	25.4 to 215.9 {1.00 to 8.50}	21.4 to 211.9 {0.84 to 8.34}	2.0 to 6.0 {0.08 to 0.24}
Die-cut label (Gap* ²) 	Roll paper 	---	25.4 to 215.9 {1.00 to 8.50}	21.4 to 211.9 {0.84 to 8.34}	2.0 to 6.0 {0.08 to 0.24}

*1: The print position is detected based on the black marks printed on the back of the paper.

*2: The print position is detected based on the gaps between labels.

Note	<p>Cautions on printing the continuous label by using the auto cutter model</p> <ul style="list-style-type: none"> <input type="checkbox"/> Remove the printed labels that are remaining in the paper ejection slot. If you continue with printing while the labels are still remaining in the paper ejection slot, the printed labels may be cut in double, or the paper may be jammed. <input type="checkbox"/> The label adhesive may adhere to the cutter, and deteriorate its cutting ability. If it becomes difficult to cut the paper, it is recommended to clean the auto cutter. <p> "Cleaning the Auto Cutter (Auto Cutter Model Only)" on page 75</p> <p>Cautions on using a die-cut label</p> <p>Depending on the shape of die-cut labels, the labels may peel off their backing paper inside the printer. In such a case, it is necessary to operate gap detectors. For details on how to operate the detectors, refer to the <i>Technical Reference Guide</i>.</p>
-------------	---

Before use

Paper Type

Supported paper types vary depending on the type of black ink as shown below.

Paper Type	CW-C6000/C6500 Series		CW-D6000/D6500 Series
	When using Matte Ink	When using Gloss Ink	Dye Ink
Plain Paper	✓	-	-
Matte Paper	✓	✓	✓
Synthetic	✓	✓	✓
Texture Paper	✓	-	-
Glossy Paper	-	✓	✓
Glossy Film	-	✓	✓
High Glossy Paper	-	✓	✓

Note	Since the CW-D6000/D6500 Series has only one type of black ink, there are no paper restrictions based on the type of black ink.  "Paper Specifications" on page 109
-------------	---

Paper That Cannot Be Used

Do not load paper like the following. Such paper will cause paper jams and print stains.

- ❑ Thermal paper



- ❑ Paper joined together by tape, etc.

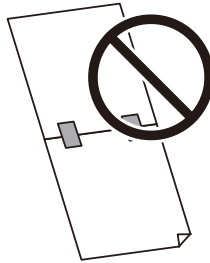

- ❑ Paper of A size, B size, etc.

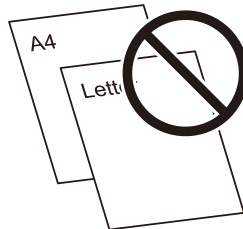

- ❑ Paper with transparent backing paper

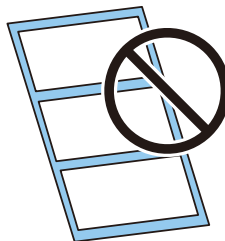

Part Names and Functions

This section describes the main operation parts.

Front

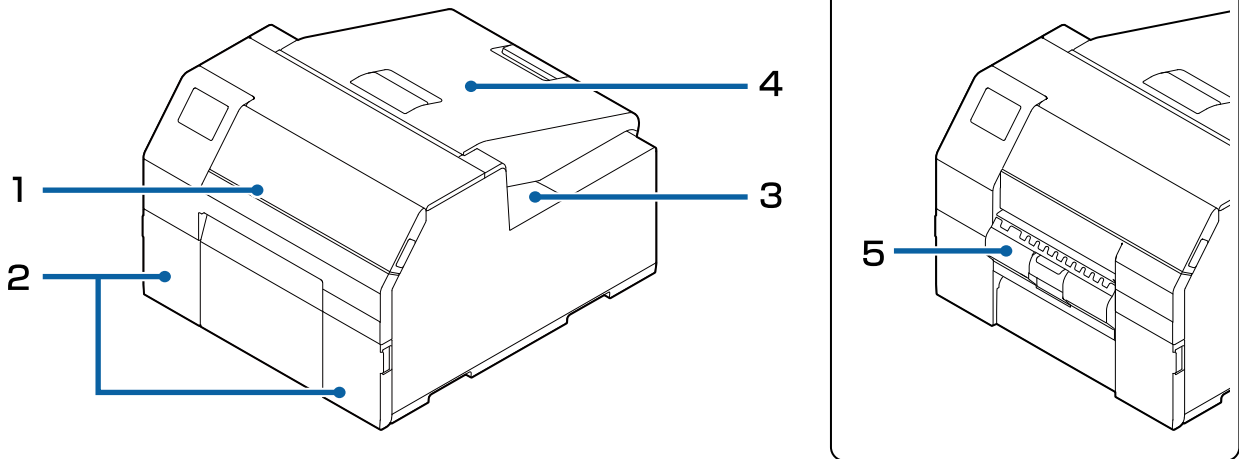

No.	Name	Description
1	Front cover	Open this cover to remove paper if it is jammed. ☞ "Paper is jammed" on page 94
2	Ink cartridge cover	Open this cover to install/replace the ink cartridge. ☞ "Replacing the Ink Cartridges" on page 35
3	Maintenance box cover	Open this cover to install/replace the maintenance box. ☞ "Replacing the Maintenance Box" on page 38
4	Paper cover	Open this cover to load or replace paper. How to open the paper cover differs depending on whether the paper is to be supplied from the inside or the outside. ☞ "Opening the Paper Cover" on page 31
5	Peeler cover (Peeler model only)	Open this cover to load paper. By passing a backing paper through the peeler, labels are printed being peeled from the backing paper. The cover is equipped with a label peeling detector, which detects whether a peeled label is remaining at the paper ejection slot or not.

Before use

Rear

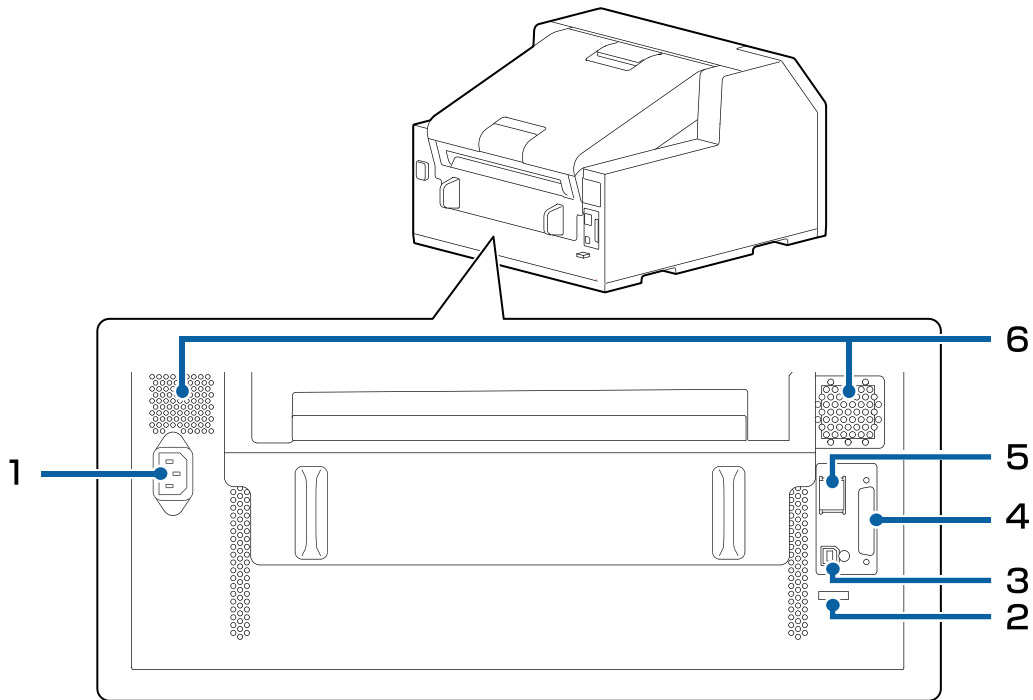

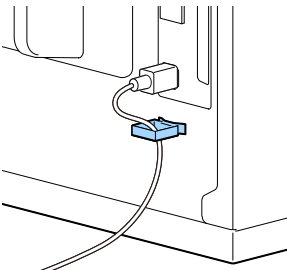
No.	Name	Description
1	AC inlet	Connect the power cable.
2	Wire saddle	Pass the USB cable through this saddle to prevent disconnection of the cable. 
3	USB port	Connect a USB cable.
4	EXT.I/F	This port is used only by specific users to control external devices.
5	LAN port	Connect a LAN cable.
6	Air vent	Exhausts heat generated in the printer to prevent the temperature inside the printer from rising. Provide a clearance of 10 cm {3.94 in.} or more from the area around the air vent to ensure ventilation when installing the printer.

Inside

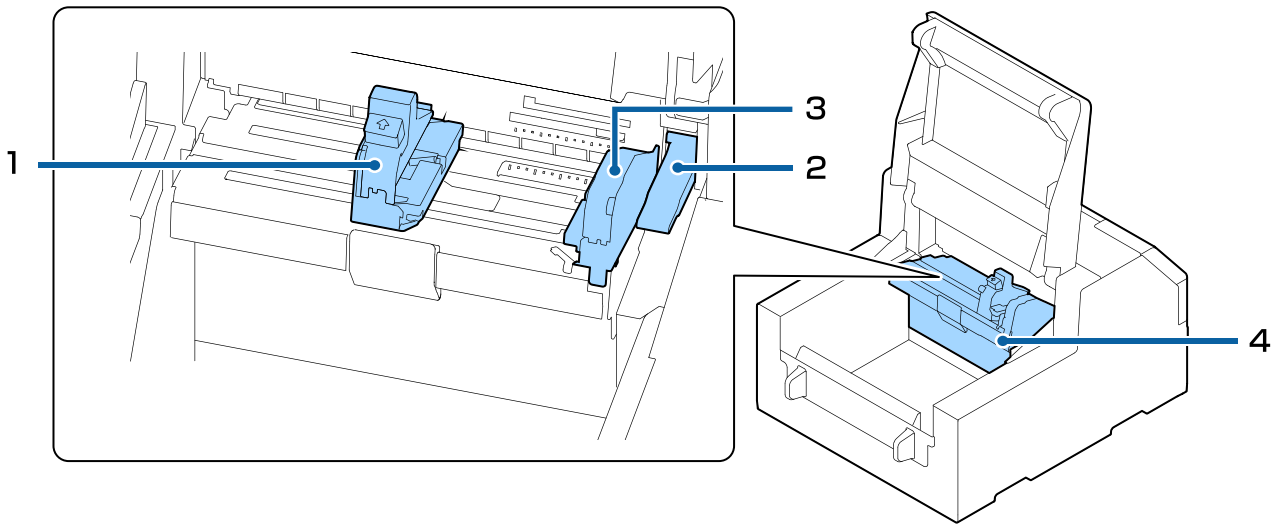

No.	Name	Description
1	Movable edge guide	Supports paper at the paper width position while the paper is fed into the printer. Squeeze the blue lever to move the guide, and position the guide so that it touches the paper edge.
2	Release lever	Use this lever when removing a jammed paper. By moving the lever up, the paper pressure rollers are unlocked and you can remove paper jammed inside the front cover.
3	Edge guide	Supports paper while the paper is fed into the printer. When loading paper, load the paper along this guide.
4	Paper guide unit	Move this unit when cleaning the paper feed roller. If you pull the blue lever, the entire unit moves, and you can check the paper feed roller.

Spindle and Flange

Used to supply the paper from the inside.

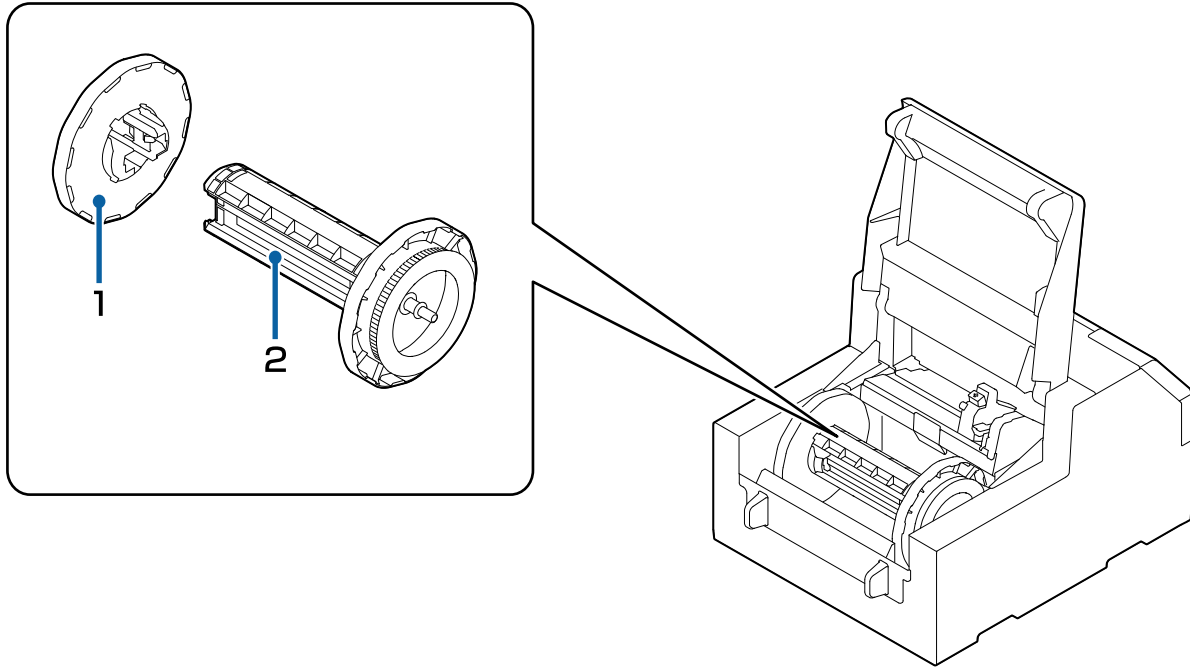





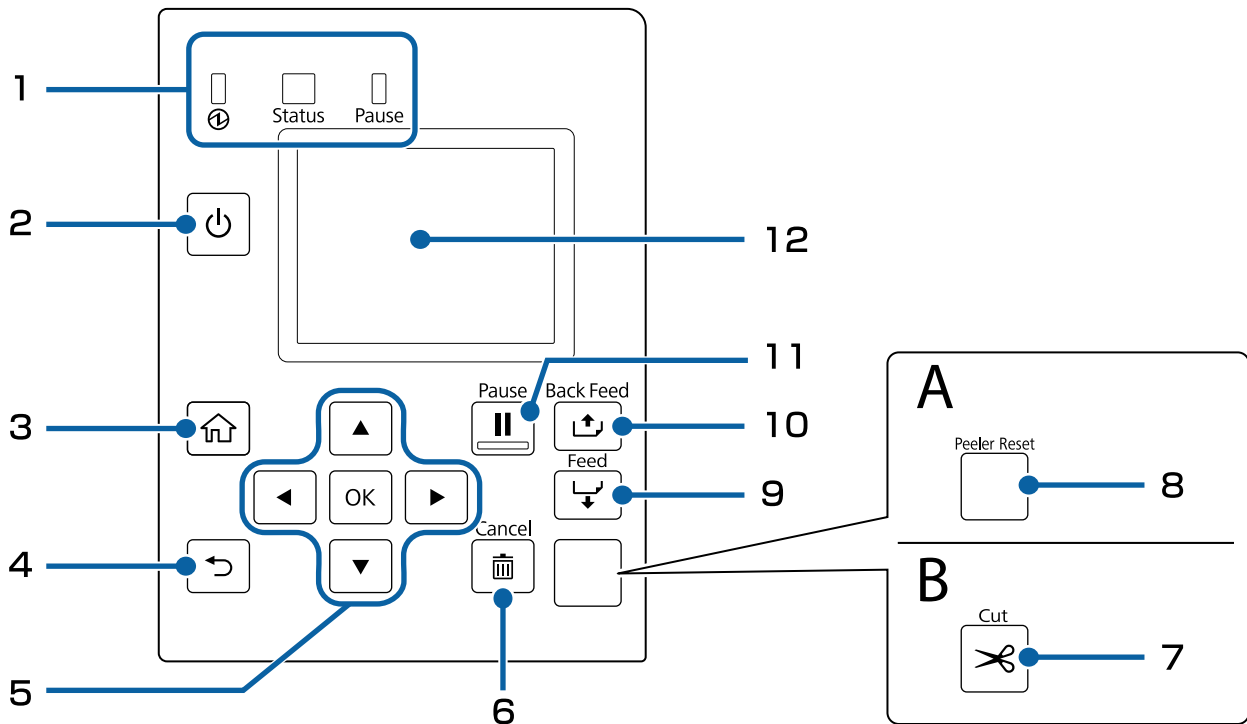

No.	Name	Description
1	Flange	Attach this to the spindle to fix the roll paper loaded on the spindle. Squeeze the blue lever to attach or remove to/from the spindle.
2	Spindle	Load roll paper on this spindle.

Operation Panel



A: Peeler model
 B: Auto cutter model

No.	Name	Description
1	LED	<p>The status of the printer can be checked from the flashing of the LEDs. This allows you to know the cause of an error and how to resolve the problem.</p> <p>For more details, see the <i>Technical Reference Guide</i>.</p> <ul style="list-style-type: none"> <input type="checkbox"/>  (power) LED Stays on while the printer is on. Flashes during printing or charging ink. <input type="checkbox"/> Status LED Stays on or flashes while an error or problem is occurring. <input type="checkbox"/> Pause LED Stays on or flashes while the printer is paused.
2	 (power) button	Turns on/off the printer.
3	 (home) button	Displays the Home screen.
4	 (back) button	Use to return to the previous screen.
5	 (arrows) buttons and OK button	Use the  buttons to select a menu item, and then press the OK button to activate the selected menu or setting.

Before use



No.	Name	Description
6	Cancel button	Use this to cancel printing. Press the Cancel button while the printer is paused, and select Next label format or All label formats on the Cancel Selection screen to cancel printing.
7	Cut button (Auto cutter model only)	Use to cut paper. The paper cannot be cut twice at the same position.
8	Peeler Reset button (Peeler model only)	Press this button if printing of the next data does not start even after removing printed labels.  "Printing is Impossible or Becomes Suddenly Impossible" on page 92
9	Feed button	Press this briefly to feed paper by one page. Hold down to feed paper continuously.
10	Back Feed button	Use to replace paper. Hold down this button to feed the paper backward until you can pull the paper out of the printer.
11	Pause button	<ul style="list-style-type: none"> <input type="checkbox"/> If pressed while printing is in progress When the printer finishes printing the page being printed, it pauses and the Pause LED lights up. Press again to resume printing and the Pause LED will turn off. <input type="checkbox"/> If pressed while the printer is ready to print The printer goes into a pause state and the Pause LED lights up. Press again to return the printer to the standby state and the Pause LED will turn off. <input type="checkbox"/> If pressed while the printer is paused due to an error The printer is released from pause and the Pause LED turns off.
12	Screen	Status of the printer, menus, and error messages are displayed.

Basic Operation



This chapter describes the basic operating procedures of the printer.

Turning On or Off

Turning the Power On

Hold down the  (power) button until the  (power) LED lights up.

Turning the Power Off

Hold down the  (power) button until a power-off confirmation message is displayed. Then select **Yes** on the confirmation screen. The  (power) LED goes out and the printer is turned off.

Opening the Paper Cover

This section describes how to open the paper cover.



Caution

Do not use the printer with the paper cover removed. Doing so will cause the printer to malfunction.

Opening the Cover using the Lever in the Front

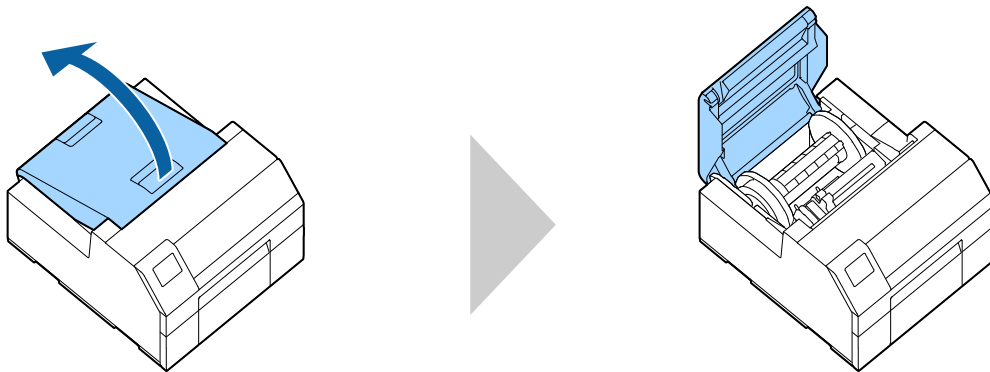

Open the paper cover as shown above for the following purposes.

- To load roll paper inside the printer, or to remove it.
- To replace the maintenance box.
- To clean inside the printer.
- To remove paper jammed inside the printer.

Opening the Cover using the Lever in the Back

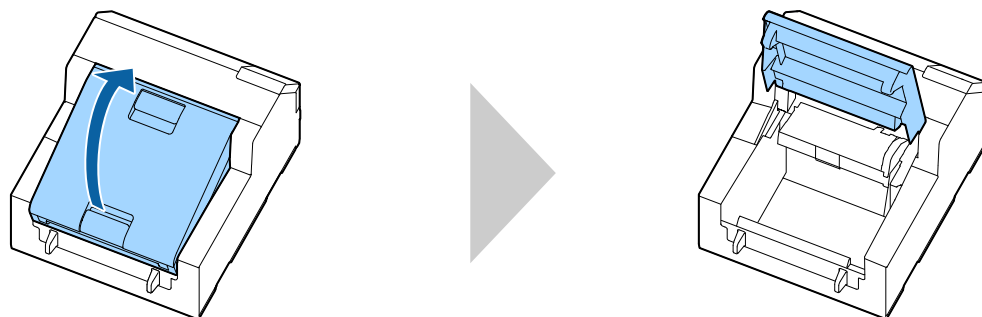

Open the paper cover as shown above for the following purposes.

- To set paper so that it is supplied from outside the printer, or to remove the paper.

Checking the Printer Status

The status of the printer can be checked from the lighting/flashing of the LEDs, and from the printer screen.

Also, by printing the status sheet, you can check the printer settings and condition of the nozzles.

[📄 “Printing Status Sheet” on page 34](#)

Checking the Paper Information

Information of currently loaded paper; paper type, paper source setting, and remaining amount of roll paper, is displayed on the home screen.

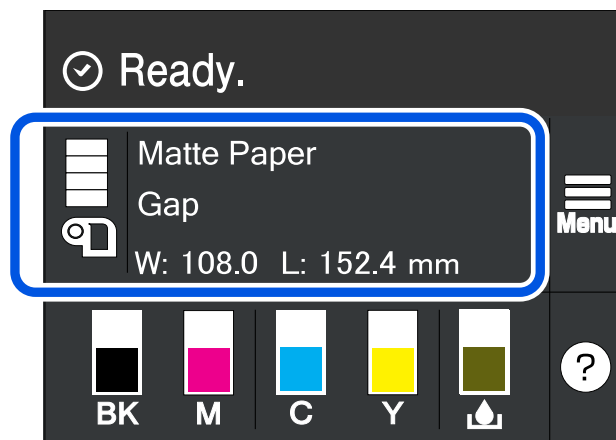

Note

Select this area to directly access the **Paper Settings** menus.

You can also make the paper settings using the printer driver.

[📄 “Printer Driver Settings” on page 41](#)

If the settings differ between the operation panel and the printer driver, the settings of the printer driver are applied.

Checking the Status of Consumables

The status of the ink cartridges and the maintenance box can be checked on the screen.

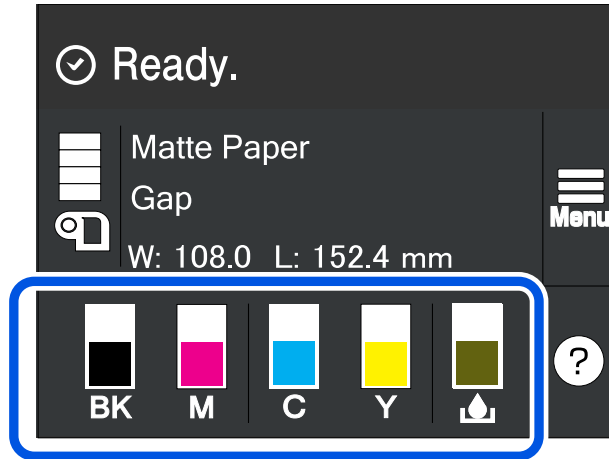

Printing Nozzle Check Patterns

By printing the nozzle check patterns, you can check the print head nozzles for clogging.

[🔗 "Printing Nozzle Check Patterns" on page 84](#)

Printing Status Sheet

By printing the status sheet, you can check the firmware version and printer settings such as the print mode and media detection settings. The following types of status sheets can be printed from the operation panel.

Menu - Printer Status/Print - Print Status Sheet

Status sheet print sample	Status sheet (network settings) print sample
<pre> <Printer Status Sheet> Sheet Output Time YYYY.MM.DD hh:mm <Basic Information> Model XX-XXXX BK Serial Number XXXXXXXX Main Firmware Version XXXXXXXX MAC Address XX:XX:XX:XX:XX:XX IP Address Setting Auto/Manual IP Address XXX.XXX.XXX.XXX Subnet Mask XXX.XXX.XXX.XXX Gateway Address XXX.XXX.XXX.XXX Head ID XXXXXXXXXXXXXXXXXXXXXXXXXXXXXXXX -- ^^^^ ^^^^ 03 xxxx yyyy/mm/dd hh:mm 04 xxxx yyyy/mm/dd hh:mm 05 xxxx yyyy/mm/dd hh:mm 06 xxxx yyyy/mm/dd hh:mm 07 xxxx yyyy/mm/dd hh:mm 08 xxxx yyyy/mm/dd hh:mm 09 xxxx yyyy/mm/dd hh:mm 10 xxxx yyyy/mm/dd hh:mm </pre>	<pre> HHH NetWork Status Sheet HHH <General Information> MAC Address xx:xx:xx:xx:xx:xx Firmware xxxxxxxx Network Status AUTO(Disconnected) <TCP/IP IPv4> Obtain IP Address Manual IP Address xxx.xxx.xxx.xxx Subnet Mask xxx.xxx.xxx.xxx Default Gateway xxx.xxx.xxx.xxx HHHHHHHHHHHH 1/1 HHHHHHHHHHHH </pre>

Note	You can also print a list of the fonts and bar codes that are already registered in the printer, or the newly registered images and templates.
-------------	--



Checking Network Connection and Settings

You can check the network connection status and settings by printing a network connection check report.

For more details, see the *Technical Reference Guide*.

Replacing the Ink Cartridges

This section describes how to replace the ink cartridges.

 Caution	<p>Carefully read the cautions on handling before installing the ink cartridges.</p> <p> "Cautions on Ink Cartridges" on page 15</p>
--	---

Checking Amount of Ink Remaining

You can check ink level of each color ink cartridge on the home or an error message screen of the operation panel.

Message	Description
You need to replace the following ink cartridge(s).	To maintain the quality of the print head, the printer stops printing before ink cartridges are completely expended. Replace the ink cartridge.

How to Replace the Ink Cartridges

The procedure below is for replacing the BK cartridge. Follow the same procedure for replacing the other color cartridges.

 Important	<p>For users of CW-C6000/C6500 Series</p> <p>When replacing the black ink cartridge, make sure to replace with a cartridge of the same type of black ink. The printer does not work if you install a cartridge of different type of black ink.</p>
--	---

- 1** Open the left ink cartridge cover.

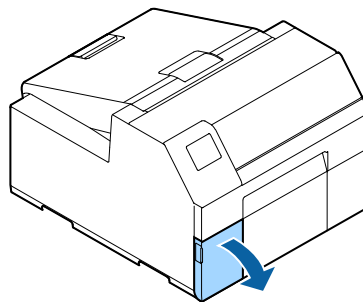

Note	For replacing cyan or yellow cartridge, open the right ink cartridge cover.
-------------	---

Basic Operation

- 2 Press the lever down to remove the used ink cartridge.

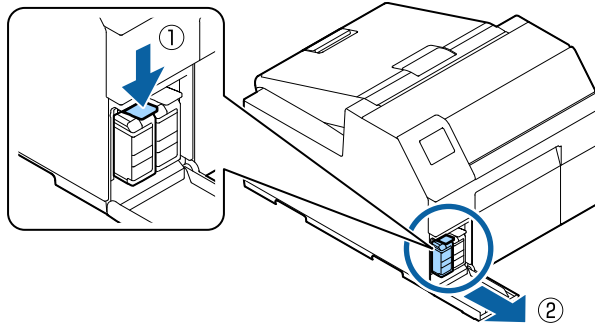

- 3 Open the bag and take out the new ink cartridge.

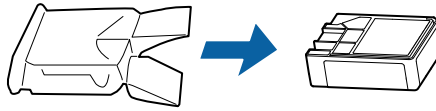

- 4 Shake the ink cartridge.

As shown in the figure below, shake the cartridge horizontally. Move the cartridge by about 5 cm to both directions, and repeat it about 15 times for about 5 seconds.

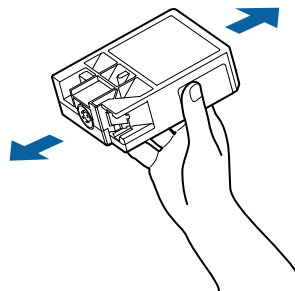

- 5 Install the ink cartridge in the slot.

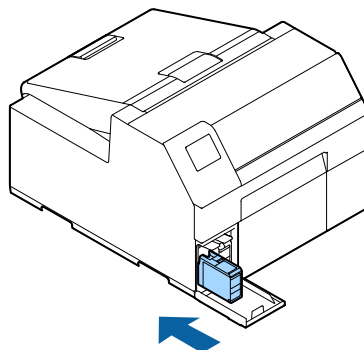

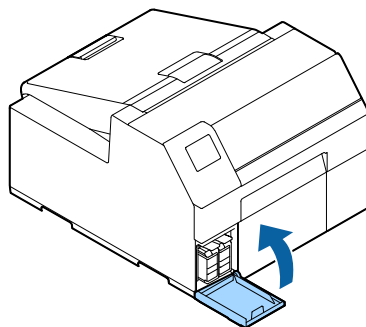

Basic Operation

- 6 Close the ink cartridge cover.



Replacing the Maintenance Box

This section describes how to replace the maintenance box.

 Caution	Carefully read the cautions on handling before setting the maintenance box.  "Cautions on the Maintenance Box" on page 17
--	---

Checking the Amount of Empty Space in the Maintenance Box

You can check the remaining capacity of the maintenance box on the home or an error message screen of the operation panel.

Message	Description
The Maintenance Box is at the end of its service life. You need to replace it.	Replace the maintenance box with a new one.

How to Replace the Maintenance Box

Note	The maintenance box is the same for the CW-C6000/C6500 Series and the CW-D6000/D6500 Series. You can install a new maintenance box to either series. However, do not install it to a printer of a different series midway through use. Doing so may hamper the maintenance box functions.
-------------	---

- 1 Open the paper cover.

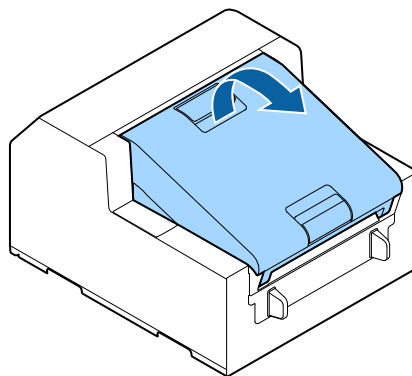

Basic Operation

- 2 Open the maintenance box cover.

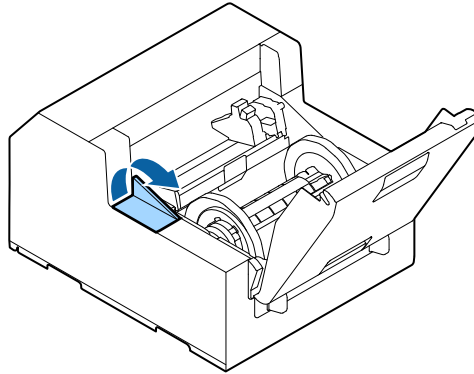

- 3 Take out the maintenance box.

When disposing of the used maintenance box, put it in a plastic bag that came with the new maintenance box.

 [“Disposal of Maintenance Box” on page 113](#)

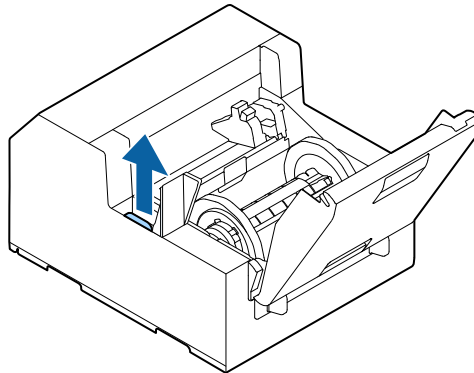

- 4 Take out a new maintenance box from the bag.

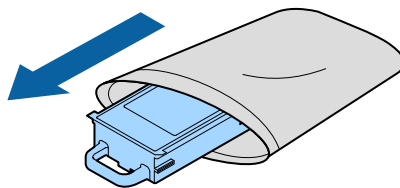

Basic Operation

- 5** Install the new maintenance box.

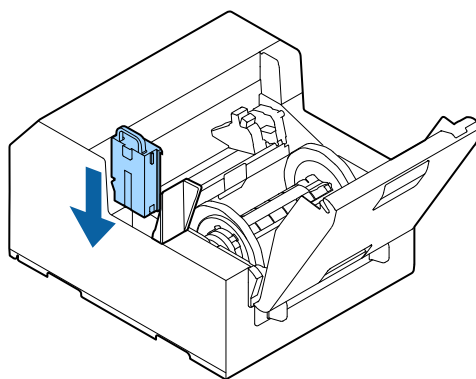

- 6** Close the maintenance box cover.

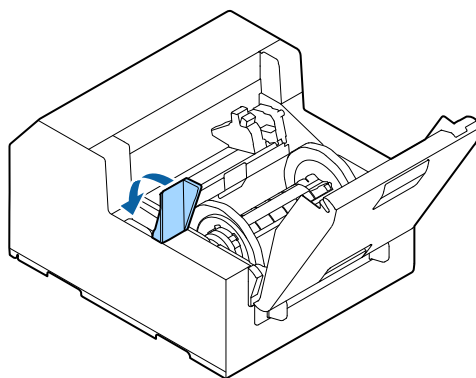

Printer Driver Settings

Set the basic items required for printing such as the size and form of media.

The printer driver is equipped with a help function. Right-click an item and then click Help to display an explanation on the item.

You can also learn how to configure the printer driver with videos. Access the videos from the following URL.

- ❑ CW-C6000/C6500 Series:

[<https://support.epson.net/p_doc/790/>](https://support.epson.net/p_doc/790/)

- ❑ CW-D6000/D6500 Series:

[<https://support.epson.net/p_doc/ab6/>](https://support.epson.net/p_doc/ab6/)

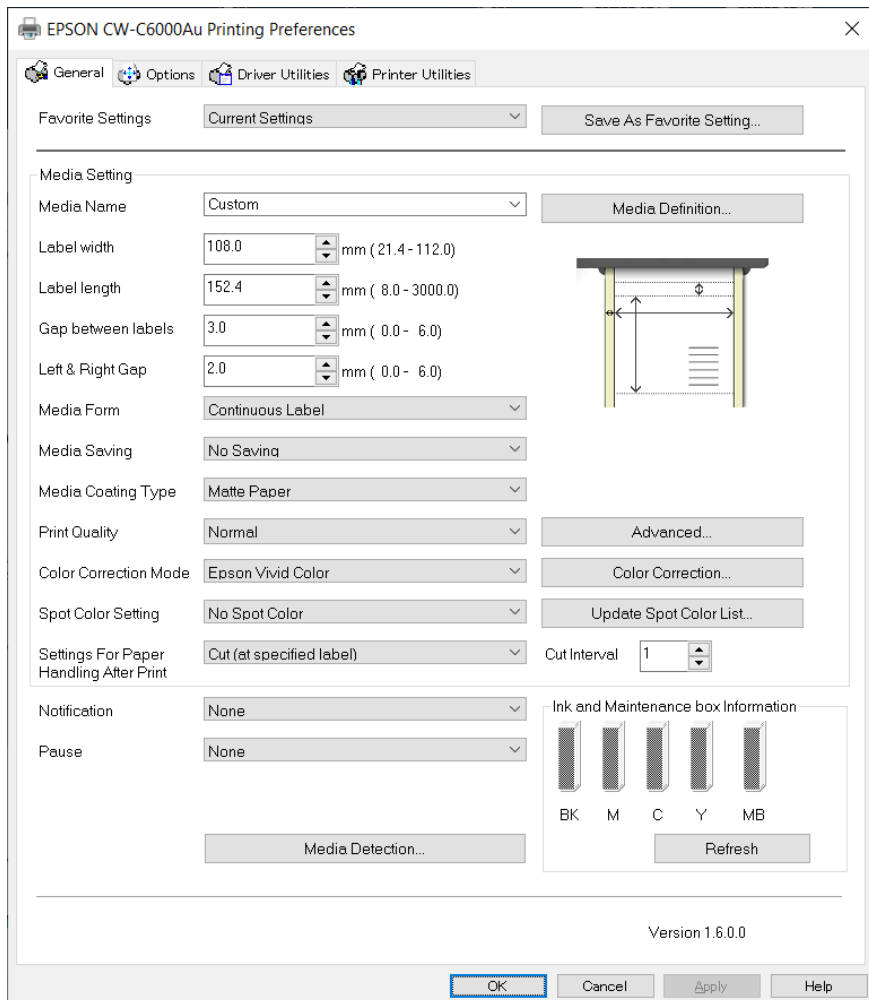

Note	If the settings on the printer (settable using the operation panel, PrinterSettings, or Web Config) differ from the printer driver settings, printing is performed by applying the printer driver settings.
-------------	---

Media Definition

The size, form, type, and other settings of frequently used paper can be registered as a media definition. The set media definition can be selected from the Media Name pull-down menu. This is convenient because you will not need to set the paper settings of the driver when printing from an application if you register a media definition in advance.

If you wish to set the paper size and other settings every time without registering a media definition, select **Custom** from the **Media Name** pull-down menu on the **General** tab. The various settings on the **General** tab will become available so that you can set the paper size and other settings.

Media Name

- 108 × 152.4 mm {4.25 × 6.00 in.} - Die-cut Label* (Initial setting)
- Custom

*: This setting is suitable for printing the roll paper included with the product.

Label width

For CW-C6000/D6000 Series

Can be specified from 21.4 to 112.0 mm {0.84 to 4.41 in.}

Initial setting: 108.0 mm {4.25 in.}

For CW-C6500/D6500 Series

Can be specified from 21.4 to 215.9 mm {0.84 to 8.50 in.}

Initial setting: 108.0 mm {4.25 in.}

Label Length

For the auto cutter model

Can be specified from 8 to 609.6 mm {0.31 to 24 in.}

Initial setting: 152.4 mm {6.00 in.}

Note	<p>If the interval for cutting the paper is less than 15.0 mm {0.59 in.}, auto cutting is not possible because a paper jam may occur. If you want to use auto cutting for labels less than 15.0 mm {0.59 in.}, set the interval for cutting the paper to 15.0 mm {0.59 in.} or more in the settings for paper handling after print.</p> <p> "Settings For Paper Handling After Print" on page 46</p>
-------------	---

For the peeler model

Can be specified from 12.7 to 609.6 mm {0.50 to 24 in.}

Initial setting: 152.4 mm {6.00 in.}

Gap between labels

When detecting paper with black marks or gaps

2 to 6 mm {0.08 to 0.24 in.}

Initial setting: 3 mm {0.12 in.}

When not detecting paper

0 to 6 mm {0 to 0.24 in.}

Initial setting: 3 mm {0.12 in.}

Left & Right gap

Can be set in a range of 0 to 6 mm {0 to 0.24 in.} (normally 2 mm {0.08 in.})

Initial setting: 2 mm {0.08 in.}

Note	If they are set larger than 2 mm {0.08 in.}, problems such as paper jams may occur.
-------------	---

Media Form

- Die-cut Label (Gap) (Initial setting)
- Die-cut Label (BlackMark)
- Continuous Label (BlackMark)
- Continuous Label
- Continuous paper (BlackMark)
- Continuous paper

Media Saving

Enabled only when [Full-page Label] is selected as the [Media Form].

- Eliminate Lower Margin
- Eliminate Lower And Upper Margin

- No Saving (Initial setting)

Media Coating Type

CW-C6000/C6500 Series

- Plain Paper
- Matte Paper (Initial setting)
- Synthetic
- Texture Paper
- Glossy Paper
- Glossy Film
- High Glossy Paper

CW-D6000/D6500 Series

- Matte Paper
- Synthetic
- Glossy Paper (Initial setting)
- Glossy Film
- High Glossy Paper

Print Quality

<i>Note</i>	If you change the Media Coating Type , the Print Quality will be automatically set to the initial setting suitable for the selected paper type.
-------------	---

CW-C6000/C6500 Series

When [Media Coating Type] is [Plain Paper]

- Max Speed
- Speed (Initial setting)
- Normal
- Quality

When [Media Coating Type] is [Matte Paper], [Synthetic], or [Texture Paper]

- Max Speed

Basic Operation

- Speed
- Normal (Initial setting)
- Quality

When [Media Coating Type] is [Glossy Paper], [Glossy Film], or [High Glossy Paper]

- Normal
- Quality (Initial setting)
- Max Quality

CW-D6000/D6500 Series

When [Media Coating Type] is [Matte Paper] or [Synthetic]

- Max Speed
- Speed
- Normal (Initial setting)
- Quality

When [Media Coating Type] is [Glossy Paper], [Glossy Film], or [High Glossy Paper]

- Normal
- Quality (Initial setting)
- Max Quality

Color Correction

- Epson Vivid Color
- Epson Preferred Color (Initial setting)
- ICM
- None

Spot Color Setting

No Spot Color (Initial setting)

Settings For Paper Handling After Print

For the auto cutter model

- Cut (after printing last label)
- Cut (at specified label)
- Cut (after last page of collate page)
- Do not cut (stop at peel position)
- Do not cut (stop at cut position) (Initial setting)
- Do not cut (stop at the print end position)

<i>Note</i>	<p>Cautions for when Label Length is set to a value less than 15.0 mm {0.59 in.}</p> <ul style="list-style-type: none"><input type="checkbox"/> Auto cutting is not possible because a paper jam may occur.<input type="checkbox"/> You can still select all the following three Cut options in Settings For Paper Handling After Print.<ul style="list-style-type: none"><input type="checkbox"/> Cut (after printing last label)<input type="checkbox"/> Cut (at specified label)<input type="checkbox"/> Cut (after last page of collate page)<input type="checkbox"/> When Settings For Paper Handling After Print - Cut (at specified label) - Cut Interval is set to "1", it is automatically changed to "2" to ensure that the label is longer than the minimum label length that can be cut (15.0 mm {0.59 in.}). Also, to ensure that the label length does not become less than the minimum label length that can be cut (15.0 mm {0.59 in.}), "1" can no longer be set for Cut Interval.
-------------	---

For the peeler model

- Manual apply (Initial setting)
- Auto apply
- Rewind

Notification

For the auto cutter model

- None (Initial setting)
- Beep at Cut
- Beep at Job End
- Beep at Collate End

For the peeler model

- None (Initial setting)
 - Beep at Job End
 - Beep at Collate End
-

Pause

For the auto cutter model

- None (Initial setting)
- Pause at Cut
- Pause at Job End
- Pause at Collate End

For the peeler model

- None (Initial setting)
 - Pause at Job End
 - Pause at Collate End
-

Media Detection...

Media Source

- Internal roll (Initial setting)
- External feed

Media Detection

- Gap detection (Initial setting)
- Black mark detection
- No detection

Loading and Replacing Paper

This section describes how to load and replace paper. As shown below, the procedure of replacing paper differs depending on the size and whether paper has been/is going to be supplied from inside or outside. Videos that show the procedure are also available.

Access the videos from the following URL.

- ❑ CW-C6000/C6500 Series:
[<https://support.epson.net/p_doc/790/>](https://support.epson.net/p_doc/790/)
- ❑ CW-D6000/D6500 Series:
[<https://support.epson.net/p_doc/ab6/>](https://support.epson.net/p_doc/ab6/)

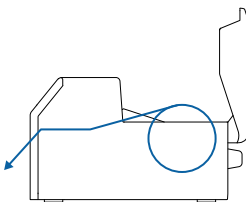
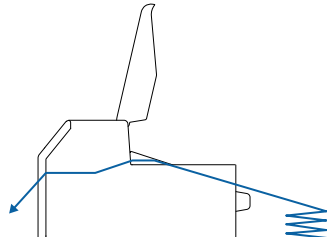
Supply from Inside (Internal)	Supply from Outside (Rear Feed)
<p>Paper is supplied from inside the printer. Set roll paper attached to the spindle into the printer.</p> 	<p>Paper is supplied from outside the printer. Place fanfold paper behind the printer. (Auto cutter model only)</p> 

<p>! Important</p>	<ul style="list-style-type: none"> ❑ To supply roll paper from outside the printer, prepare an external paper feeder and paper rewriter by yourself. For more details, see the <i>Technical Reference Guide</i>. ❑ With the peeler model, you can not supply fanfold paper from outside the printer. ❑ When replacing paper with a different shape, form, or type of paper, change the paper settings either from the operation panel or on the printer driver before loading the paper. <p>👉 "Checking the Paper Information" on page 32</p> <p>👉 "Printer Driver Settings" on page 41</p>
----------------------------------	--

How to supply paper	Procedures for auto cutter model	Procedures for peeler model
Supply from Inside (Internal)	"How to Load Paper (Auto Cutter Model - Supply from Inside)" on page 50	"How to Load Paper (Peeler Model - Supply from Inside)" on page 60
	"How to Remove Paper (For the Auto Cutter Model)" on page 67	"How to Remove Paper (For the Peeler Model)" on page 69
	"How to Eject Paper at Paper End (For the Auto Cutter Model)" on page 71	"How to Eject Paper at Paper End (For the Peeler Model)" on page 72

Basic Operation

How to supply paper	Procedures for auto cutter model	Procedures for peeler model
Supply from Outside (Rear Feed)	"How to Load Paper (Auto Cutter Model - Supply from Outside)" on page 55	---
	"How to Remove Paper (For the Auto Cutter Model)" on page 67	
	"How to Eject Paper at Paper End (For the Auto Cutter Model)" on page 71	

How to Load Paper (Auto Cutter Model - Supply from Inside)



Caution

After turning on the printer, wait until the home screen is displayed, and then open the paper cover. If you open the cover before the home screen is displayed, the printer may fail to load the paper correctly.

- 1 Turn on the printer, and then check that **Internal** is selected as the **Media Source** setting on the operation panel.

 [“Checking the Paper Information” on page 32](#)

- 2 Open the paper cover.

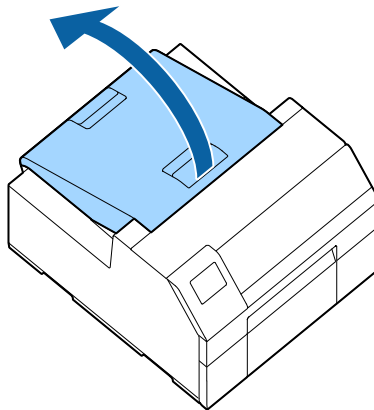

- 3 Remove the spindle from the printer.

As shown in the figure, hold the spindle and flange with both hands, and remove them.

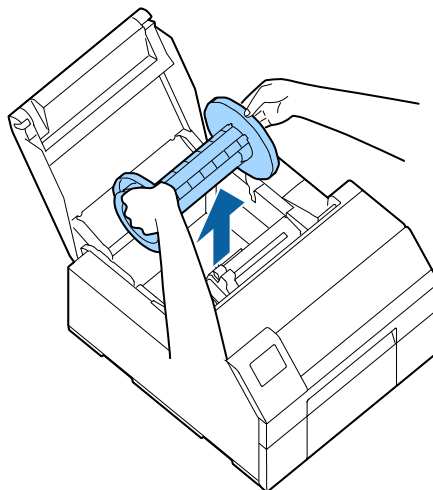

Basic Operation

4 Load the roll paper on the spindle and fix it with the flange.

- ❑ To move the flange, squeeze the two levers.
- ❑ When loading the roll paper on the spindle, take note of the winding direction. The correct winding direction is marked on the spindle.
- ❑ Fix the flange and roll paper so that there is no gap in between.

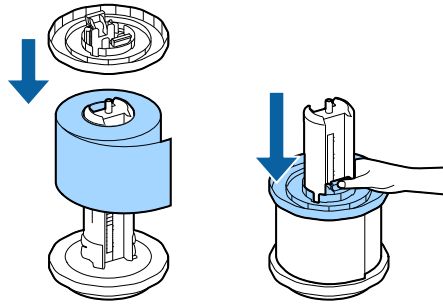

5 Hold the spindle with both hands, and set it in the printer.

Install the spindle so that both ends of the spindle fit into the holders inside the printer.

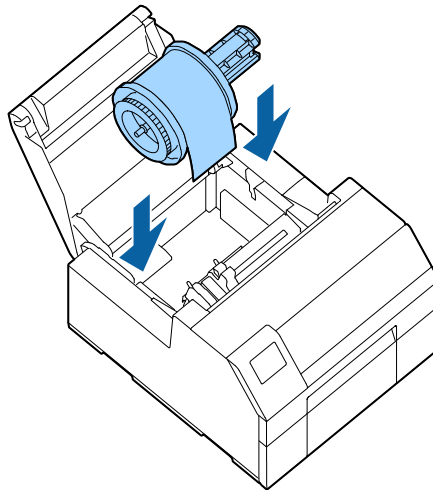

6 Slide the movable edge guide to the right side.

Squeeze the blue lever to move the edge guide.

Basic Operation

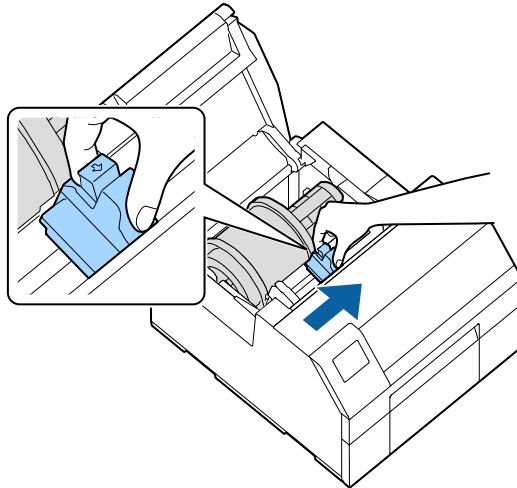

7 Pull the paper along the left edge guide.

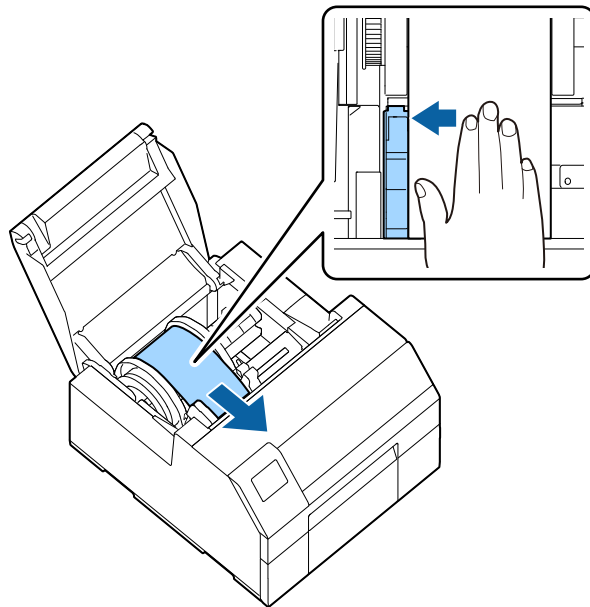

8 Place your hand on the paper to flatten it, and slide the movable edge guide against the paper.

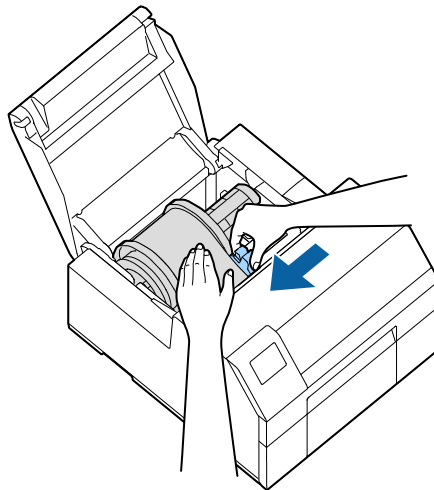

Basic Operation

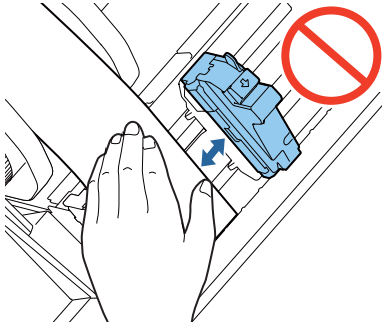
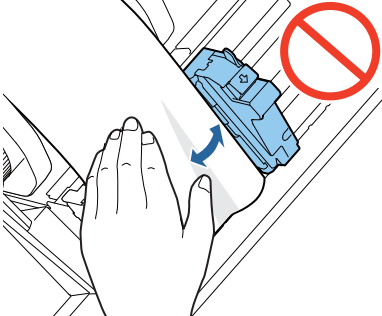
<p> Caution</p>	<p>If the movable edge guide is not properly slid against the paper, print position may become incorrect or a paper jam may occur. Make sure to follow the guidelines below.</p> <ul style="list-style-type: none">❑ There should be no gap between the guide and the paper edge.  <ul style="list-style-type: none">❑ Do not slide the guide against the paper too tightly. 
---	--

9

Insert the paper into the paper feed slot until paper feeding starts automatically.

Do not load backing paper that has no labels on it. The paper may not be detected and not be fed automatically.

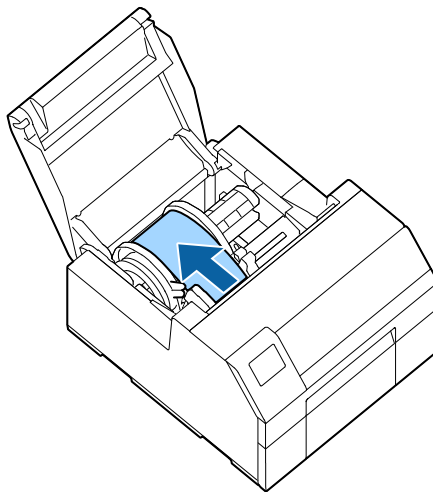

Basic Operation

- 10 Rotate the spindle to remove looseness in the paper.

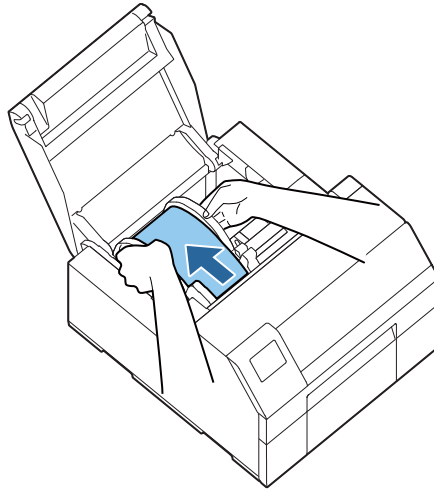

- 11 Close the paper cover.

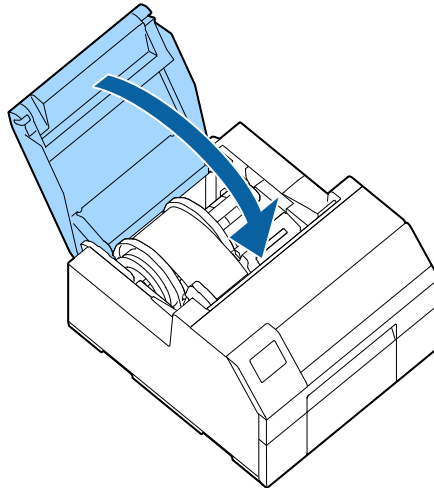

- 12 Press the **Pause** button.

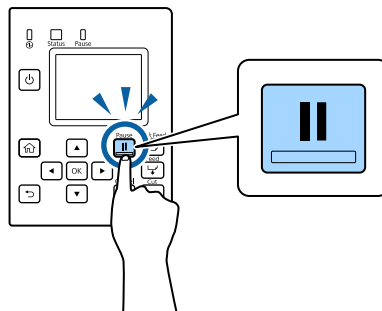

Loading paper (auto cutter model - supply from inside) is now completed.

How to Load Paper (Auto Cutter Model - Supply from Outside)



Caution

After turning on the printer, wait until the home screen is displayed, and then open the paper cover. If you open the cover before the home screen is displayed, the printer may fail to load the paper correctly.

- 1 Turn on the printer, and then check that **Rear Feed** is selected as the **Media Source** setting on the operation panel.

 [“Checking the Paper Information” on page 32](#)

- 2 Open the paper cover.

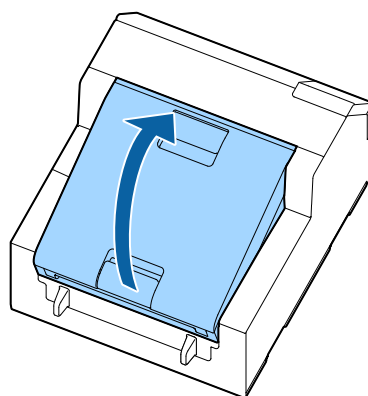

- 3 Remove the spindle, if present.

As shown in the figure, hold the spindle and flange with both hands, and remove them.

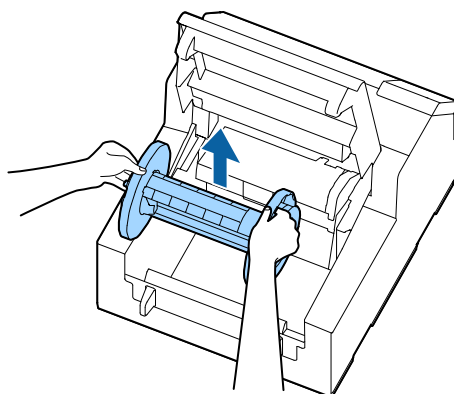



Basic Operation

4

Place the fanfold paper behind the printer.

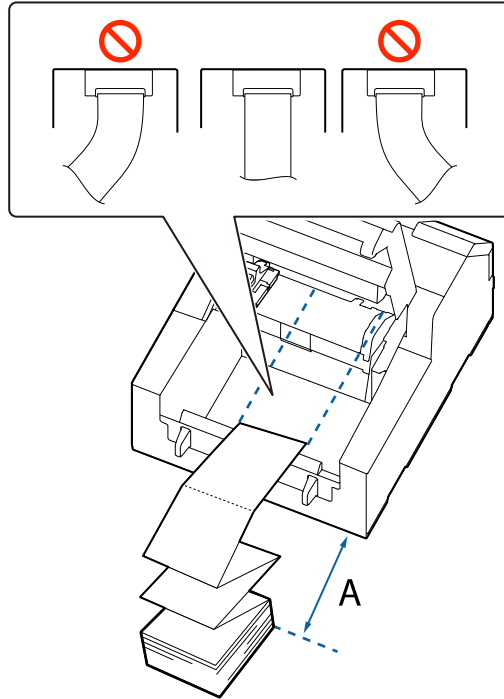
- ❑ Place the fanfold paper at least 100 mm {3.94 in.} (A in the figure) away from the printer.
- ❑ Make sure the paper is vertical in relation to the paper feed slot.

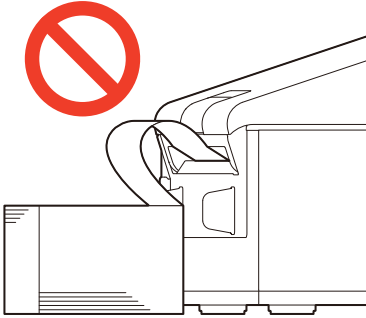

 Caution	<p>Make sure not to let the fanfold paper to curl near the printer. Doing so will deform the paper resulting in a paper jam or a print quality problem.</p> 
--	--

5

Slide the movable edge guide to the left side.

Squeeze the blue lever to move the edge guide.

Basic Operation

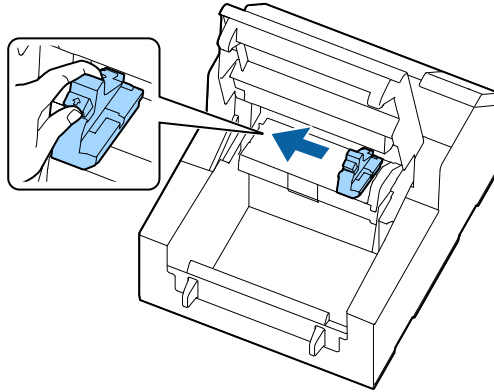

6 Pull the paper along the right edge guide.

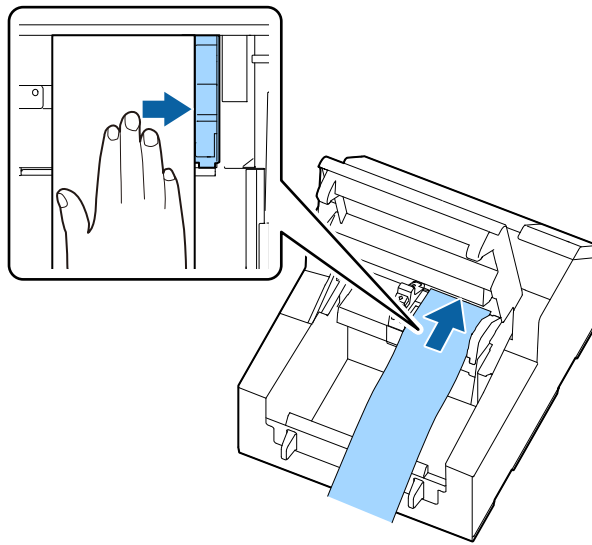

7 Place your hand on the paper to flatten it, and slide the movable edge guide against the paper.

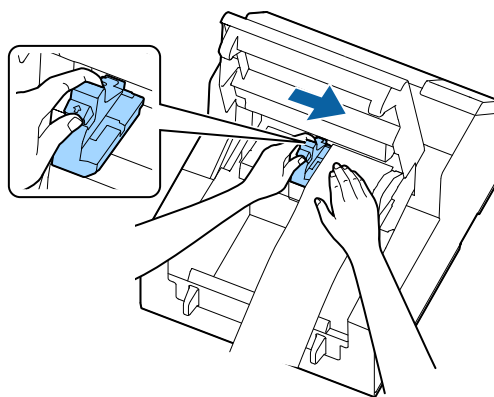

Basic Operation

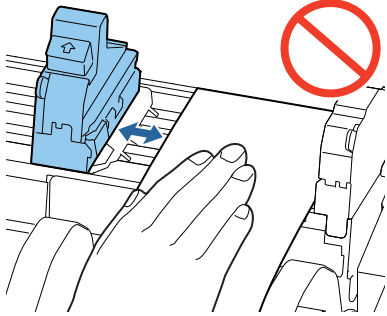
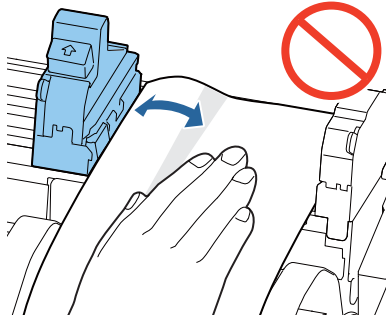
 Caution	<p>If the movable edge guide is not properly slid against the paper, print position may become incorrect or a paper jam may occur. Make sure to follow the guidelines below.</p> <ul style="list-style-type: none">❑ There should be no gap between the guide and the paper edge. 
	<ul style="list-style-type: none">❑ Do not slide the guide against the paper too tightly. 

8

Insert the paper into the paper feed slot until paper feeding starts automatically.

Do not load backing paper that has no labels on it. The paper may not be detected and not be fed automatically.

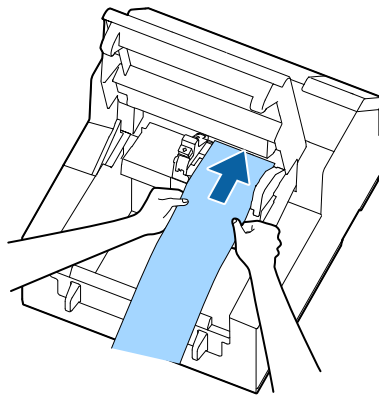

Basic Operation

- 9 Close the paper cover.

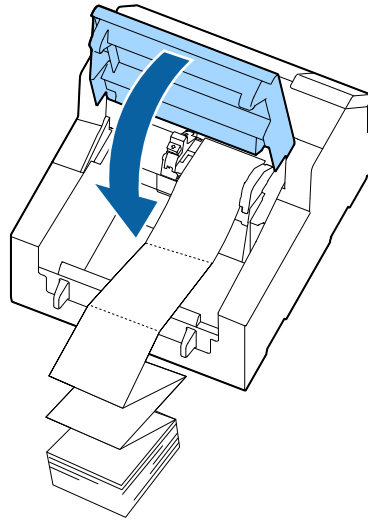

- 10 Press the **Pause** button.

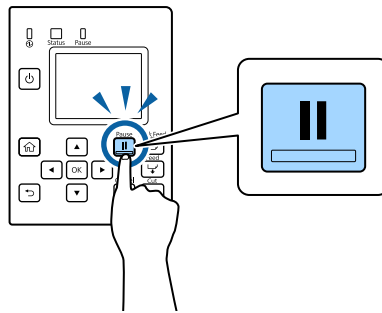

Loading paper (auto cutter model - supply from outside) is now completed.

How to Load Paper (Peeler Model - Supply from Inside)



Caution

After turning on the printer, wait until the home screen is displayed, and then open the paper cover. If you open the cover before the home screen is displayed, the printer may fail to load the paper correctly.

- 1 Turn on the printer, and then check that **Internal** is selected as the **Media Source** setting on the operation panel.

 [“Checking the Paper Information” on page 32](#)

- 2 Open the paper cover.

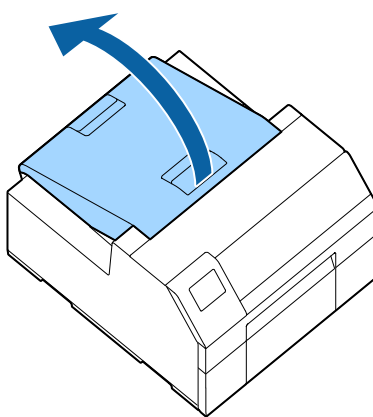

- 3 Remove the spindle from the printer.

As shown in the figure, hold the spindle and flange with both hands, and remove them.

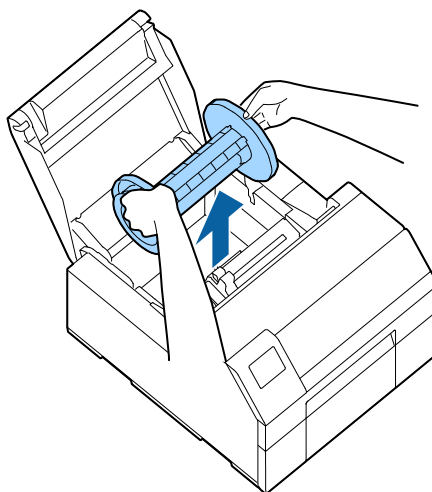

Basic Operation

4 Load the roll paper on the spindle and fix it with the flange.

- ❑ To move the flange, squeeze the two levers.
- ❑ When loading the roll paper on the spindle, take note of the winding direction. The correct winding direction is marked on the spindle.
- ❑ Fix the flange and roll paper so that there is no gap in between.

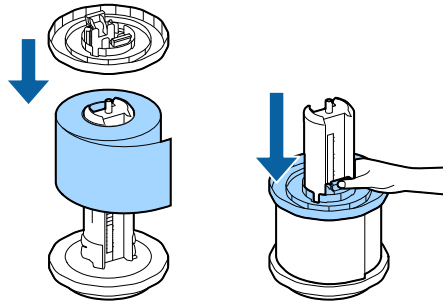

5 Hold the spindle with both hands, and set it in the printer.

Install the spindle so that both ends of the spindle fit into the holders inside the printer.

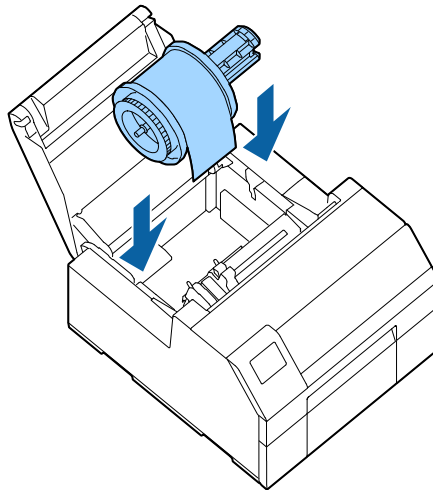

6 Slide the movable edge guide to the right side.

Squeeze the blue lever to move the edge guide.

Basic Operation

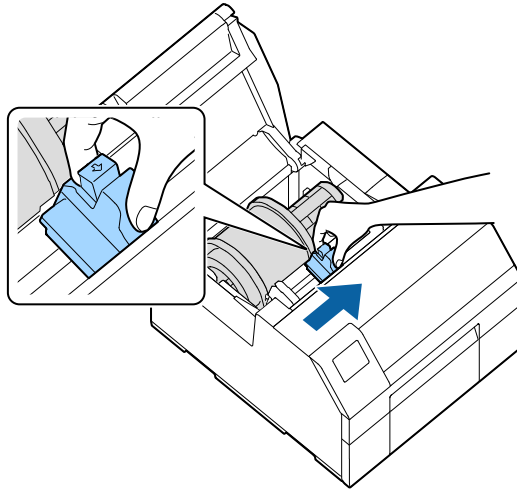

- 7** Pull the paper along the left edge guide.

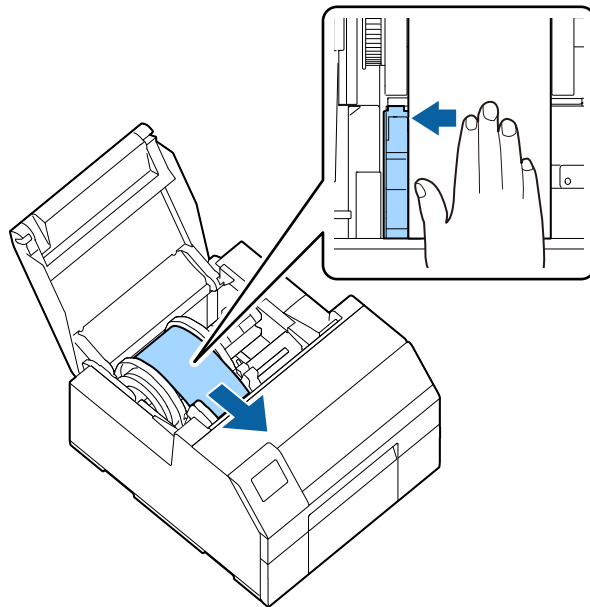

- 8** Place your hand on the paper to flatten it, and slide the movable edge guide against the paper.

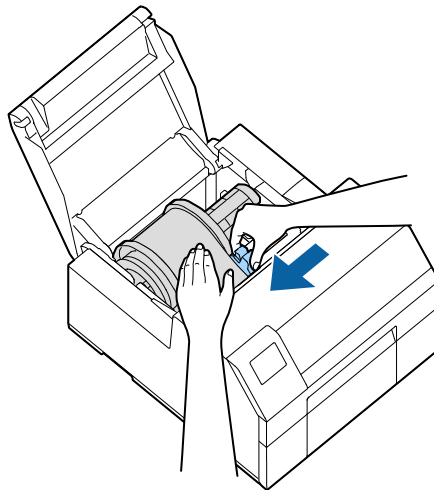

Basic Operation

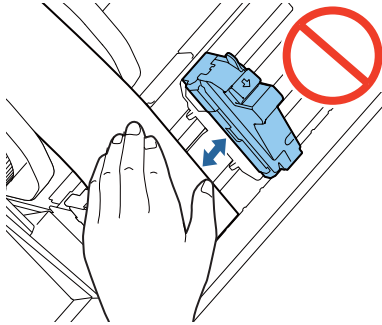
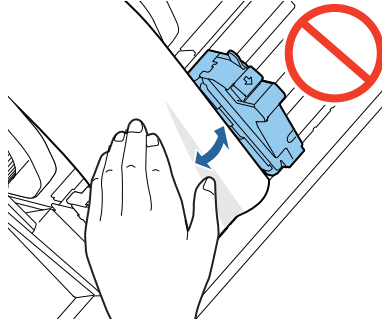
 Caution	<p>If the movable edge guide is not properly slid against the paper, print position may become incorrect or a paper jam may occur. Make sure to follow the guidelines below.</p> <ul style="list-style-type: none">❑ There should be no gap between the guide and the paper edge.  <ul style="list-style-type: none">❑ Do not slide the guide against the paper too tightly. 
--	--

9

Insert the paper into the paper feed slot until paper feeding starts automatically.

Do not load backing paper that has no labels on it. The paper may not be detected and not be fed automatically.

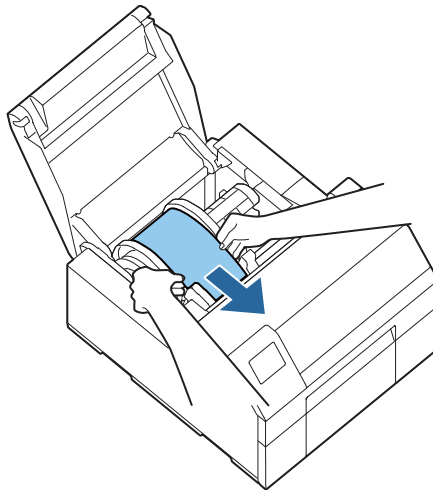

Basic Operation

- 10 Rotate the spindle to remove looseness in the paper.

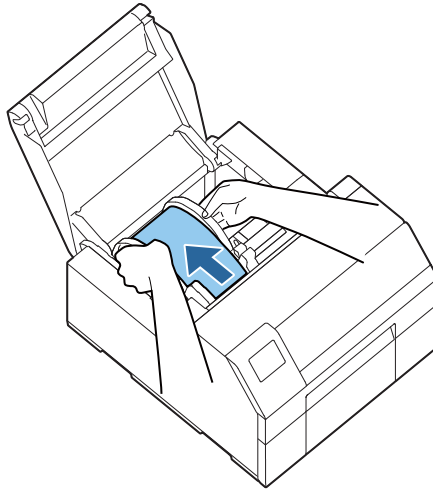

- 11 Close the paper cover.

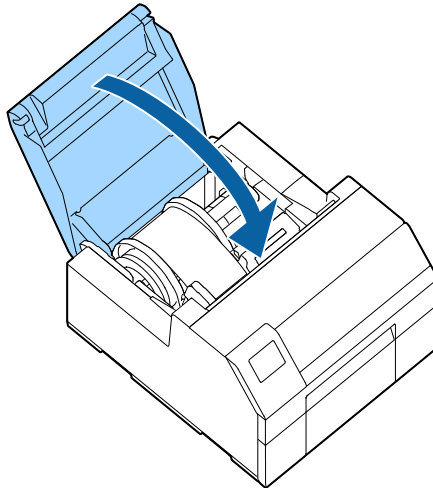

- 12 Hold down the **Feed** button until the leading edge of paper touches the table on which the printer is installed.

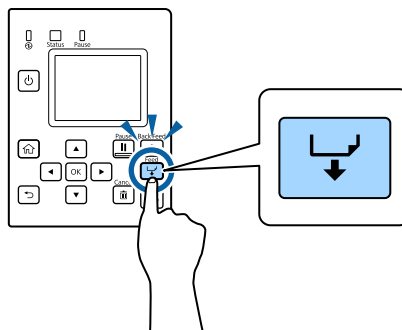

Basic Operation

- 13 Remove labels from the ejected paper.

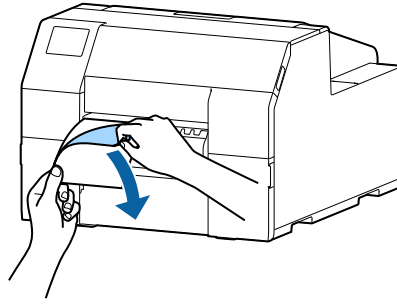

- 14 Open the peeler cover.

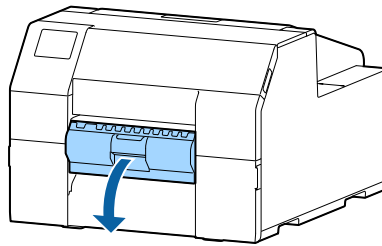

- 15 Pass the paper through the peeler slot (A).

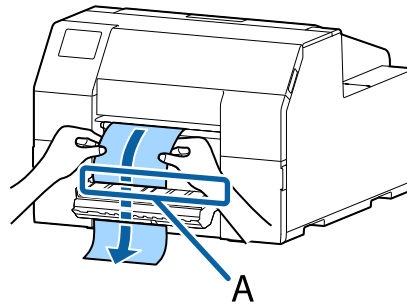

- 16 Before closing the peeler cover, load the paper along the protrusion A.

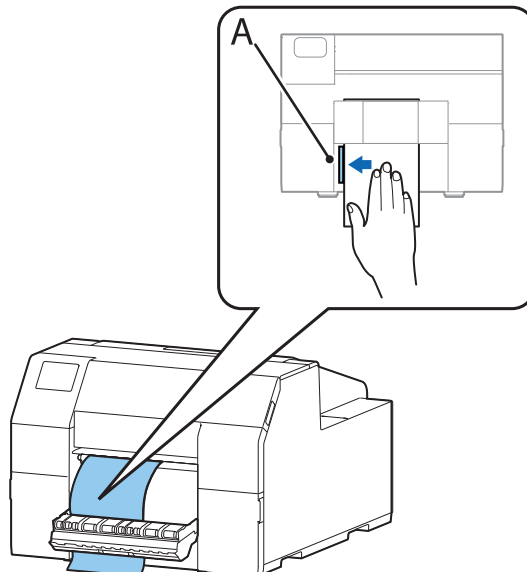

Basic Operation

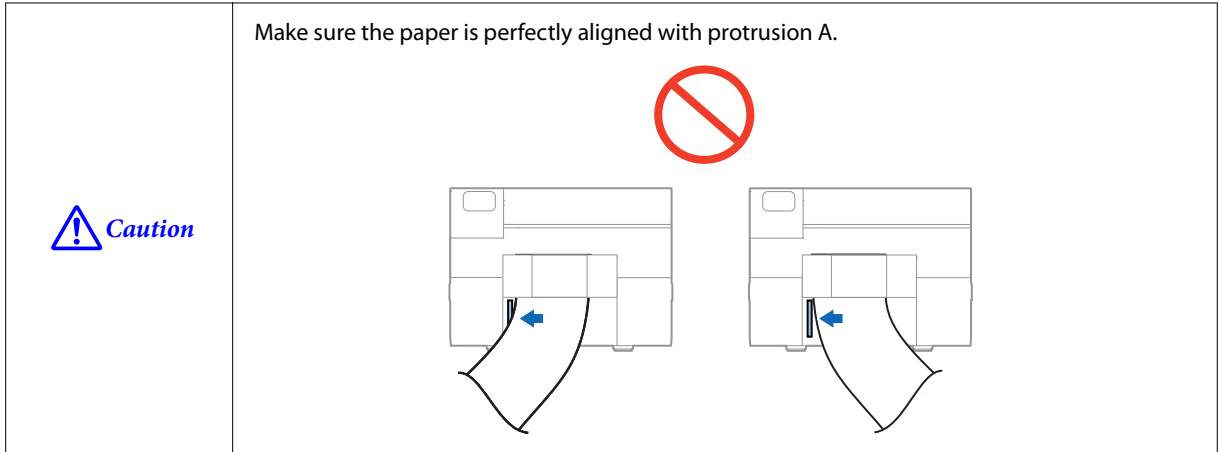

17

Close the peeler cover.

If the paper is loose, pull the leading edge of paper to remove the looseness and then close the peeler cover.

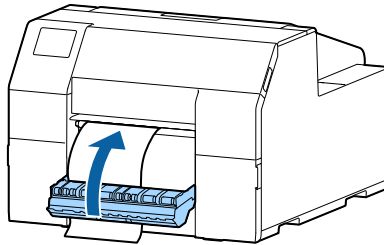

18

Press the **Pause** button.

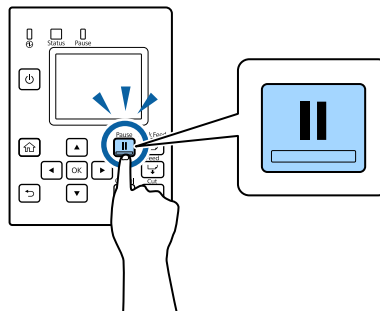

Loading paper (peeler model - supply from inside) is now completed.

How to Remove Paper (For the Auto Cutter Model)

1 Check that the printer has been turned on.

2 Press the **Cut** button, and cut off the ejected labels.

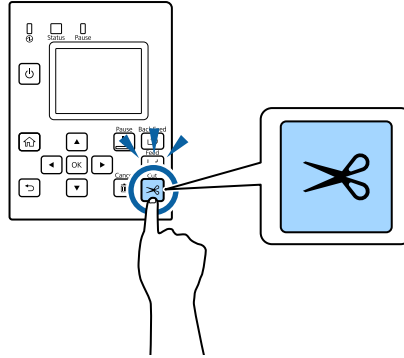

3 Press the **Back Feed** button to feed the paper backward.

The paper can now be pulled out from inside the printer.

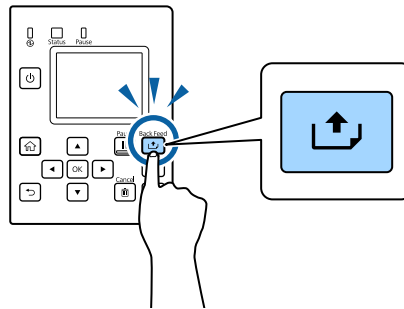

4 Open the paper cover.

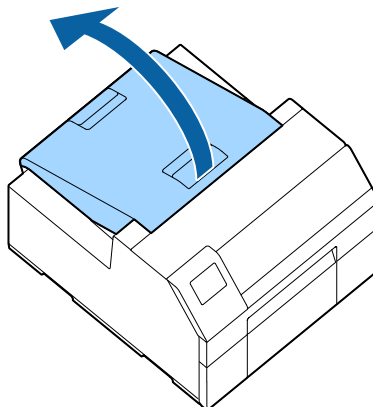

Basic Operation

- 5 Slide the movable edge guide away from the paper, and remove the paper.

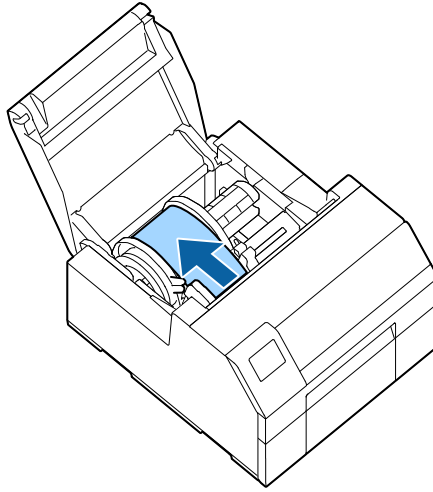

- 6 Close the paper cover.

- 7 Press the **Pause** button.

Removing the paper is now completed.

To load paper, see [“How to Load Paper \(Auto Cutter Model - Supply from Inside\)”](#) on page 50 or [“How to Load Paper \(Auto Cutter Model - Supply from Outside\)”](#) on page 55.

How to Remove Paper (For the Peeler Model)

1 Check that the printer has been turned on.

2 Open the peeler cover.

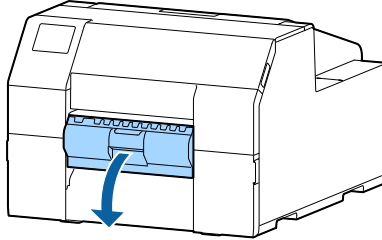

3 Cut the backing paper near the paper ejection slot.

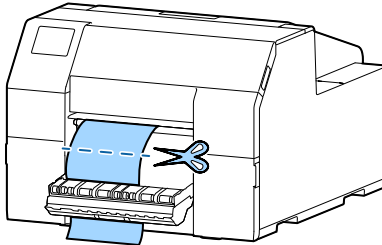

4 Press the **Back Feed** button to feed the paper backward.

The paper can now be pulled out from inside the printer.

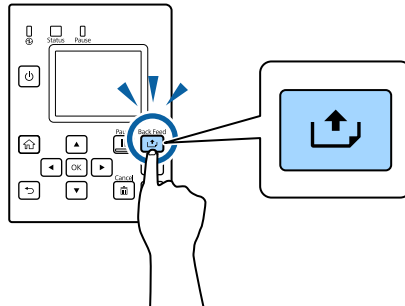

5 Open the paper cover.

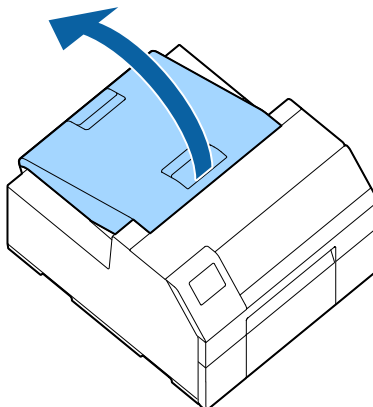

Basic Operation

- 6 Slide the movable edge guide away from the paper, and remove the paper.

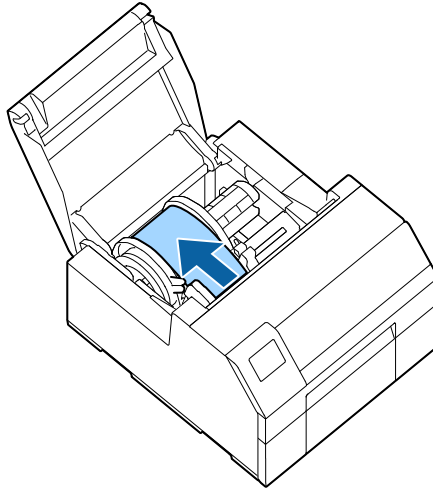

- 7 Close the paper cover.

- 8 Press the **Pause** button.

Removing the paper is now completed.

To load paper, see [“How to Load Paper \(Peeler Model - Supply from Inside\)”](#) on page 60.

How to Eject Paper at Paper End (For the Auto Cutter Model)

- 1 Hold down the Feed button until the paper is completely ejected.

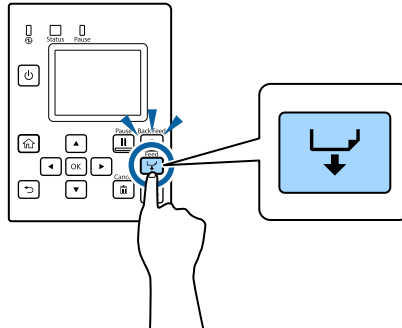

Ejecting paper at paper end is now completed.

To load paper, see [“How to Load Paper \(Auto Cutter Model - Supply from Inside\)”](#) on page 50 or [“How to Load Paper \(Auto Cutter Model - Supply from Outside\)”](#) on page 55.

How to Eject Paper at Paper End (For the Peeler Model)

- 1 Open the peeler cover.

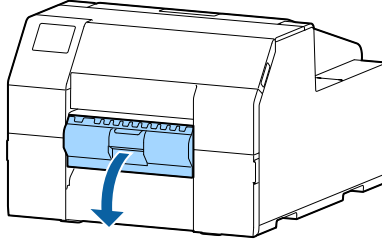

- 2 Remove the paper from the peeler slot (A).

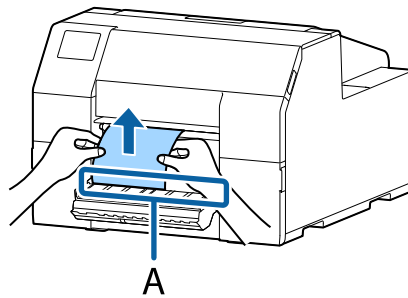

- 3 Hold down the Feed button until the paper is completely ejected.

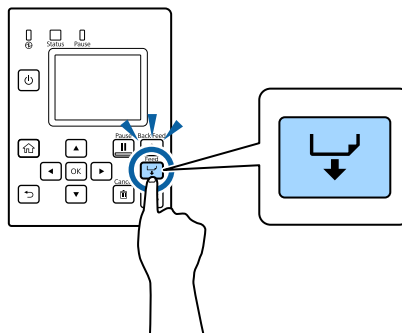

Ejecting paper at paper end is now completed.

To load paper, see [“How to Load Paper \(Peeler Model - Supply from Inside\)”](#) on page 60.

Maintenance

This chapter describes how to carry out maintenance of the printer.

Front

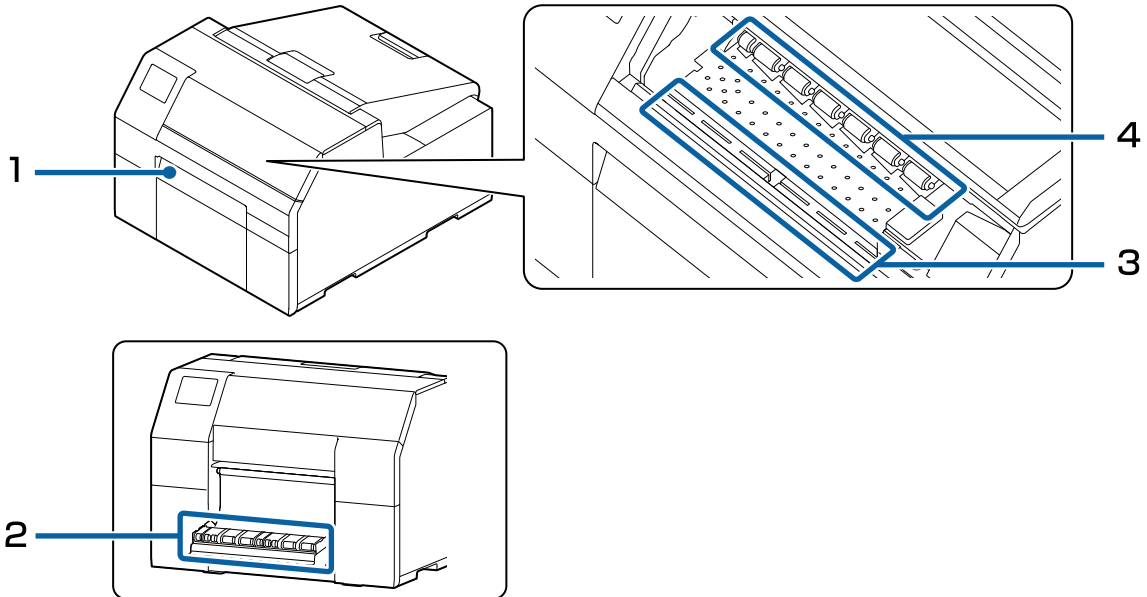

No.	Refer to:
1	"Cleaning the Auto Cutter (Auto Cutter Model Only)" on page 75
2	"Cleaning the Peeler (Peeler Model Only)" on page 77
3	"Cleaning the Platen" on page 79
4	"Cleaning the Paper Feed Roller" on page 80

Rear

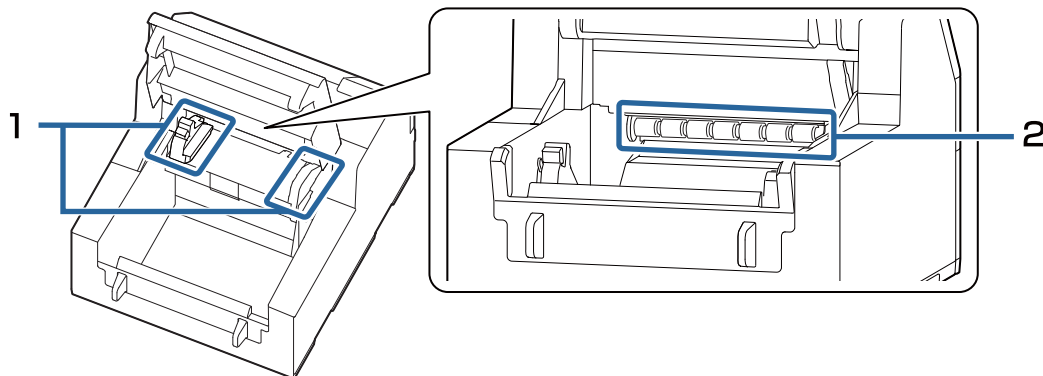

No.	Refer to:
1	"Cleaning the Edge Guides" on page 78

Maintenance

No.	Refer to:
2	 "Cleaning the Paper Feed Roller" on page 80

Cleaning the Exterior



Caution

Do not use alcohol, benzine, thinner, trichloroethylene, or ketone based solvent to clean the exterior of the printer. Doing so may deform or damage the plastic and rubber parts.

- 1** Turn the printer off and then disconnect the power cable from the outlet.
- 2** Wipe off any dirt with a dry cloth or cloth that has been slightly dampened.

Cleaning the Auto Cutter (Auto Cutter Model Only)

If labels, paper dust, or adhesive has adhered to the fixed blade (A) of the auto cutter, the blade may become dull.

Perform cleaning by following the steps below.

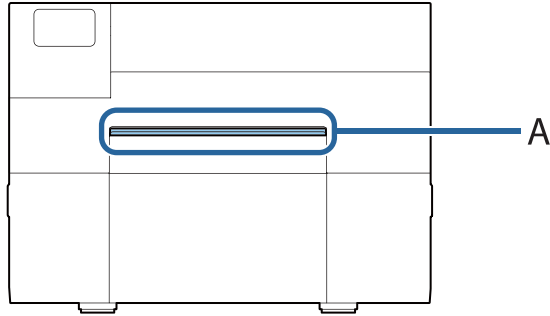

- 1** If paper has been loaded, remove it.
[🔗 “How to Remove Paper \(For the Auto Cutter Model\)” on page 67](#)
- 2** Turn the printer off and then disconnect the power cable from the outlet.

Maintenance

3

As shown in the figure below, scrape off adhered materials stuck to the fixed blade using a flat-blade screwdriver (blade width: 1.8 mm to 3.0 mm {0.07 to 0.12 in.}). Start scraping from each end toward the center.

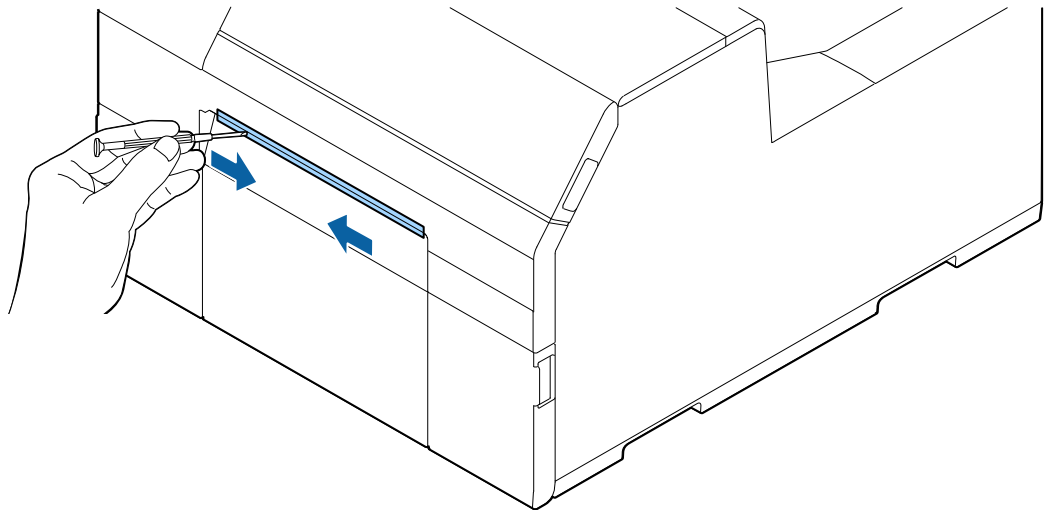
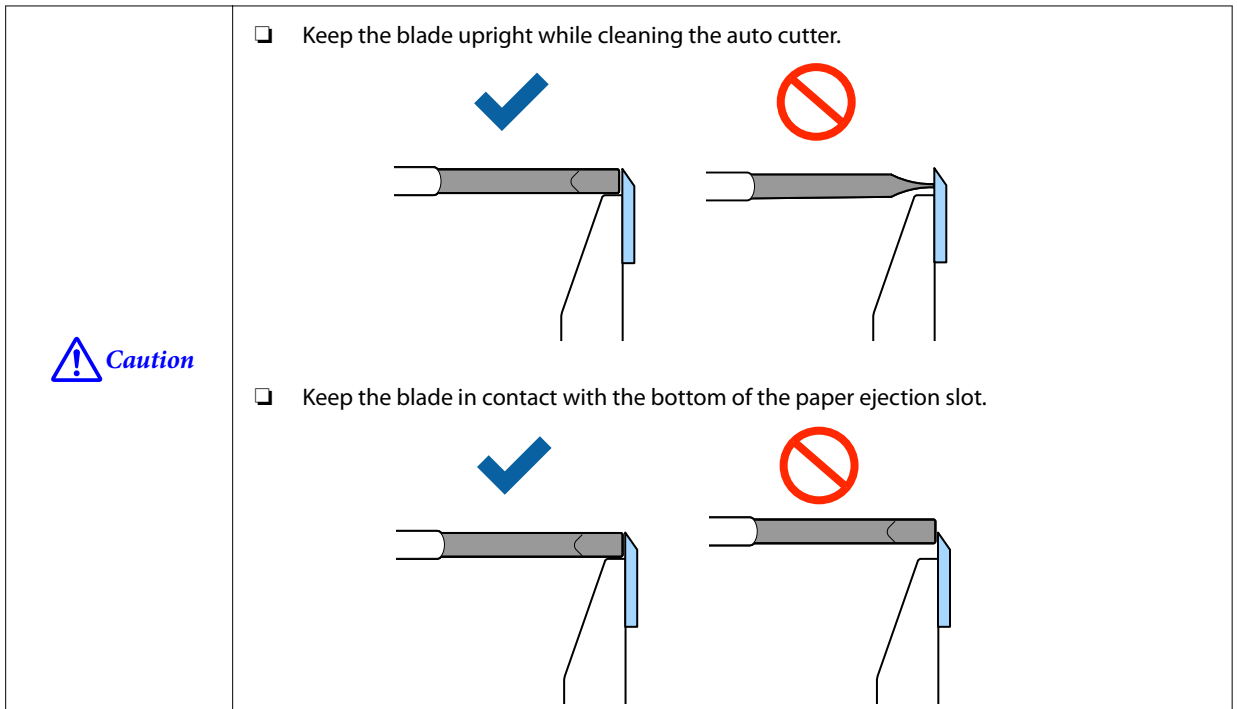

Cleaning the Peeler (Peeler Model Only)

If labels, paper dust, or adhesive has adhered to the peeler, the print quality may decline.

To maintain good print quality, it is recommended to clean the peeler every day.

Perform cleaning by following the steps below.

1 Check that the printer has been turned off.

2 Open the peeler cover.

If paper has been loaded, remove it.

 [“How to Remove Paper \(For the Peeler Model\)” on page 69](#)

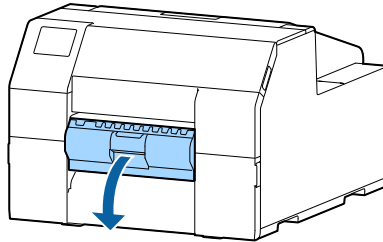

3 Clean the roller using a cotton swab moistened with alcohol.

Completely remove dirt from the roller.

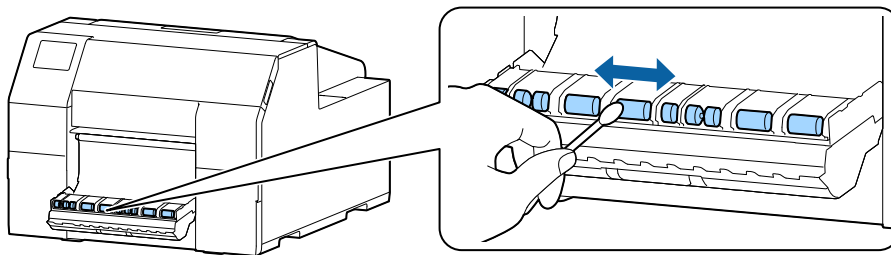

Cleaning the Edge Guides

If labels, paper dust, or adhesive has adhered to the edge guides, paper may get jammed, or printing position may become incorrect.

Perform cleaning by following the steps below.

1 Check that the printer has been turned off.

2 Open the paper cover.

If paper has been loaded, remove it.

 [“How to Remove Paper \(For the Auto Cutter Model\)” on page 67](#)

 [“How to Remove Paper \(For the Peeler Model\)” on page 69](#)

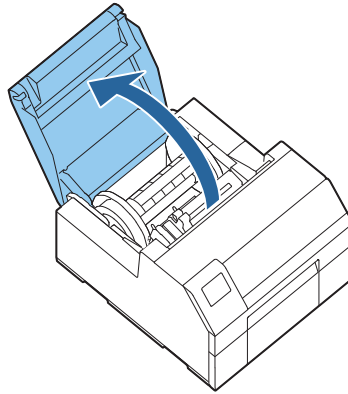

3 Clean the edge guides using a cotton swab moistened with alcohol.

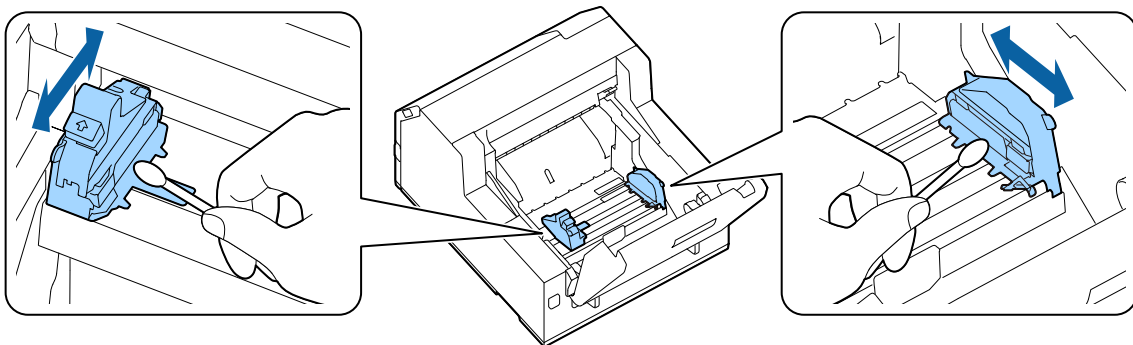

Cleaning the Platen

If labels, paper dust, or adhesive has adhered to the platen, paper may get jammed, or printing position may become incorrect.

Perform cleaning by following the steps below.

- 1 Check that the printer has been turned off.
- 2 If paper has been loaded, remove it.
[👉 “How to Remove Paper \(For the Auto Cutter Model\)” on page 67](#)
[👉 “How to Remove Paper \(For the Peeler Model\)” on page 69](#)
- 3 Open the front cover.
- 4 Raise the paper holder unit.

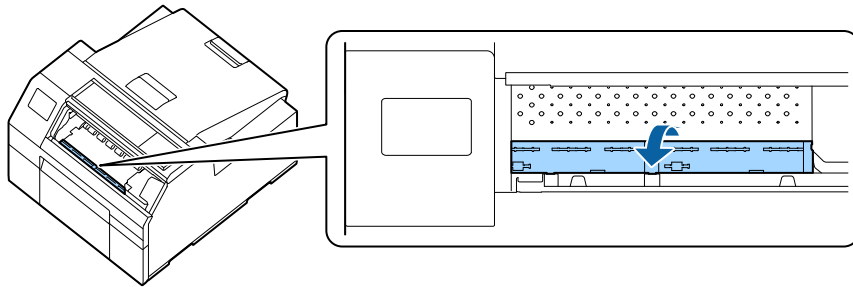

- 5 Use a cloth or cotton swab to remove adhesive adhered to the platen.

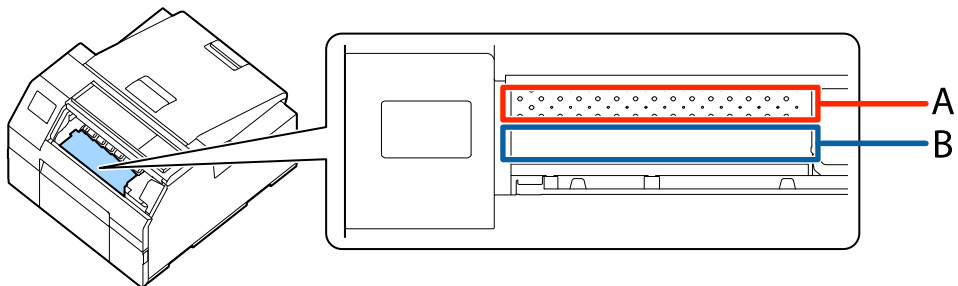

- A: Do not clean this area
- B: Clean this area

- 6 Lower the paper holder unit.

Cleaning the Paper Feed Roller

If paper dust or adhesive has adhered to the paper feed roller, paper may get jammed, or faint or blurred image may be printed.

To maintain good print quality, it is recommended that the rollers are cleaned once a week.

Perform cleaning by following the steps below.



Caution

When cleaning the paper feed roller, do not use a material other than labels. Doing so may damage the roller resulting in paper jam, or faint or blurred printout.

1 Check that the printer has been turned off.

2 Open the paper cover.

If paper has been loaded, remove it.

 [“How to Remove Paper \(For the Auto Cutter Model\)” on page 67](#)

 [“How to Remove Paper \(For the Peeler Model\)” on page 69](#)

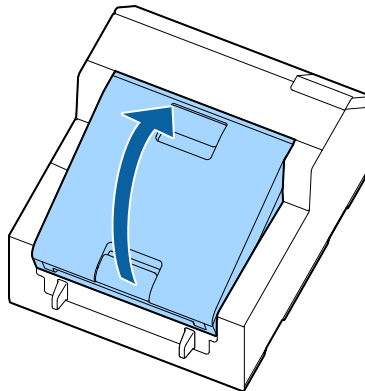

3 Remove the spindle.

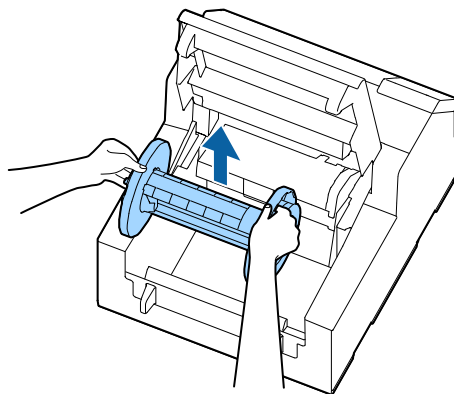

Maintenance

- 4 Raise the release lever.

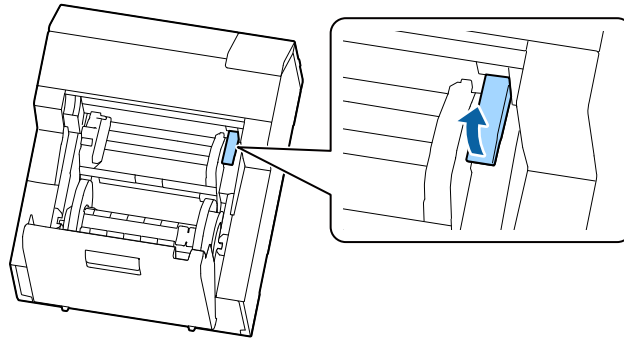

- 5 Open the paper guide unit.

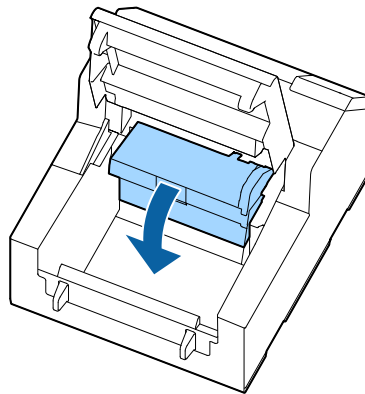

- 6 Attach adhesive side of a label to the roller, and peel it off slowly. Repeat this action until paper dust or adhesive is completely removed from side to side of the roller.

If some labels have stuck on the roller, carefully remove them as they can cause a paper jam.

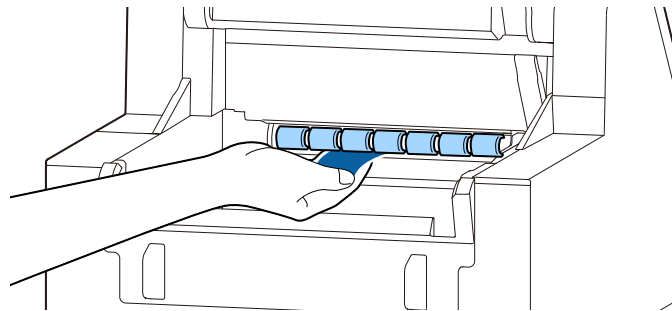

- 7 Rotate the roller by hand to remove paper dust and adhesive from the entire surface of the roller.

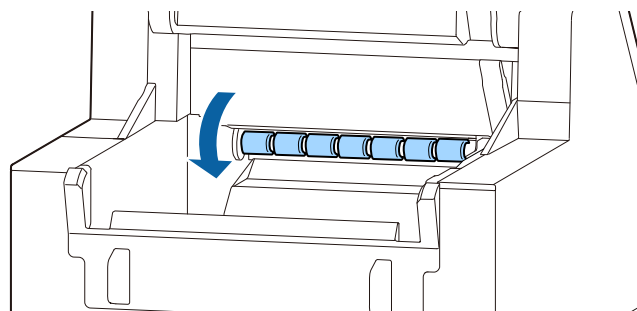

Cleaning the Paper Pressure Roller

If paper dust or adhesive has adhered to the paper pressure roller, paper may get jammed, or faint or blurred image may be printed.

Perform cleaning by following the steps below.



Caution

When cleaning the paper pressure roller, do not use a material other than labels. Doing so may damage the roller resulting in paper jam, or faint or blurred printout.

1 Check that the printer has been turned off.

2 Open the paper cover.

If paper has been loaded, remove it.

 [“How to Remove Paper \(For the Auto Cutter Model\)” on page 67](#)

 [“How to Remove Paper \(For the Peeler Model\)” on page 69](#)

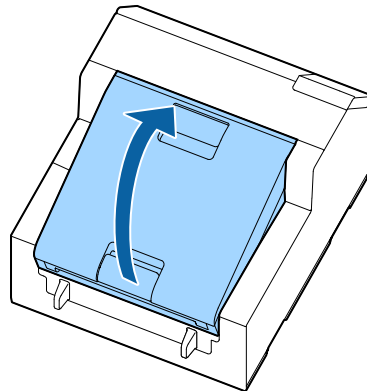

3 Remove the spindle.

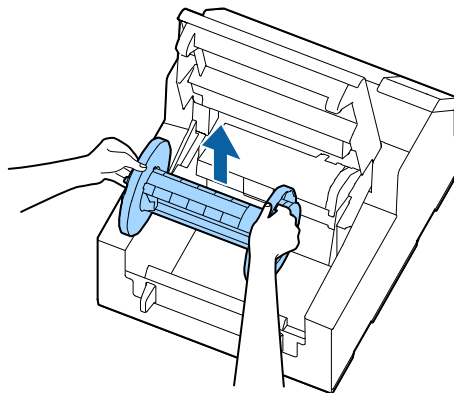

Maintenance

- 4 Raise the release lever.

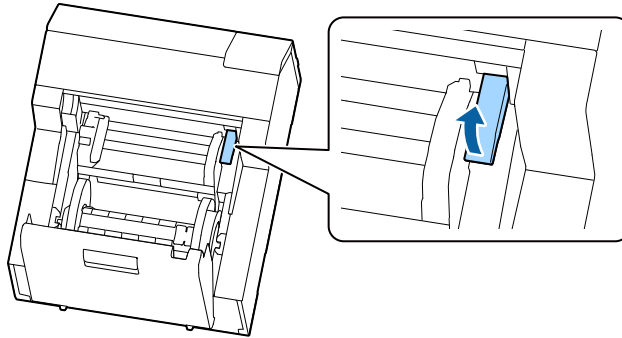

- 5 Open the front cover.

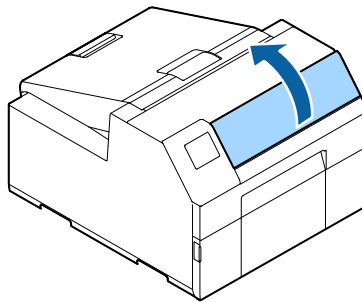

- 6 Attach adhesive side of a label to the roller, and peel it off slowly. Repeat this action until paper dust or adhesive is completely removed from side to side of the roller.

If some labels have stuck on the roller, carefully remove them as they can cause a paper jam.

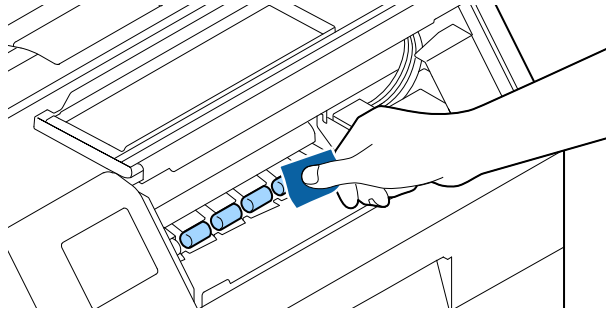

- 7 Rotate the roller by hand to remove paper dust and adhesive from the entire surface of the roller.

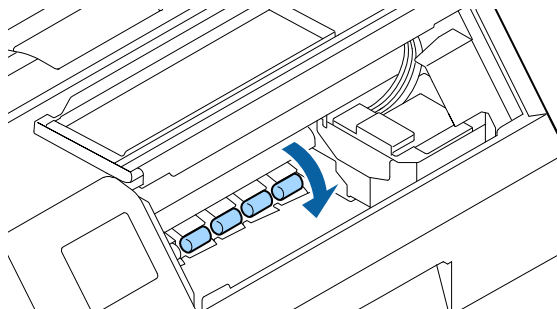

Cleaning the Print Head

If the nozzles are clogged, faint colors, banding, or unintended colors appear on printouts. When such print quality problems occur, print nozzle check patterns and check for nozzle clogging.

Example of the nozzle check patterns.

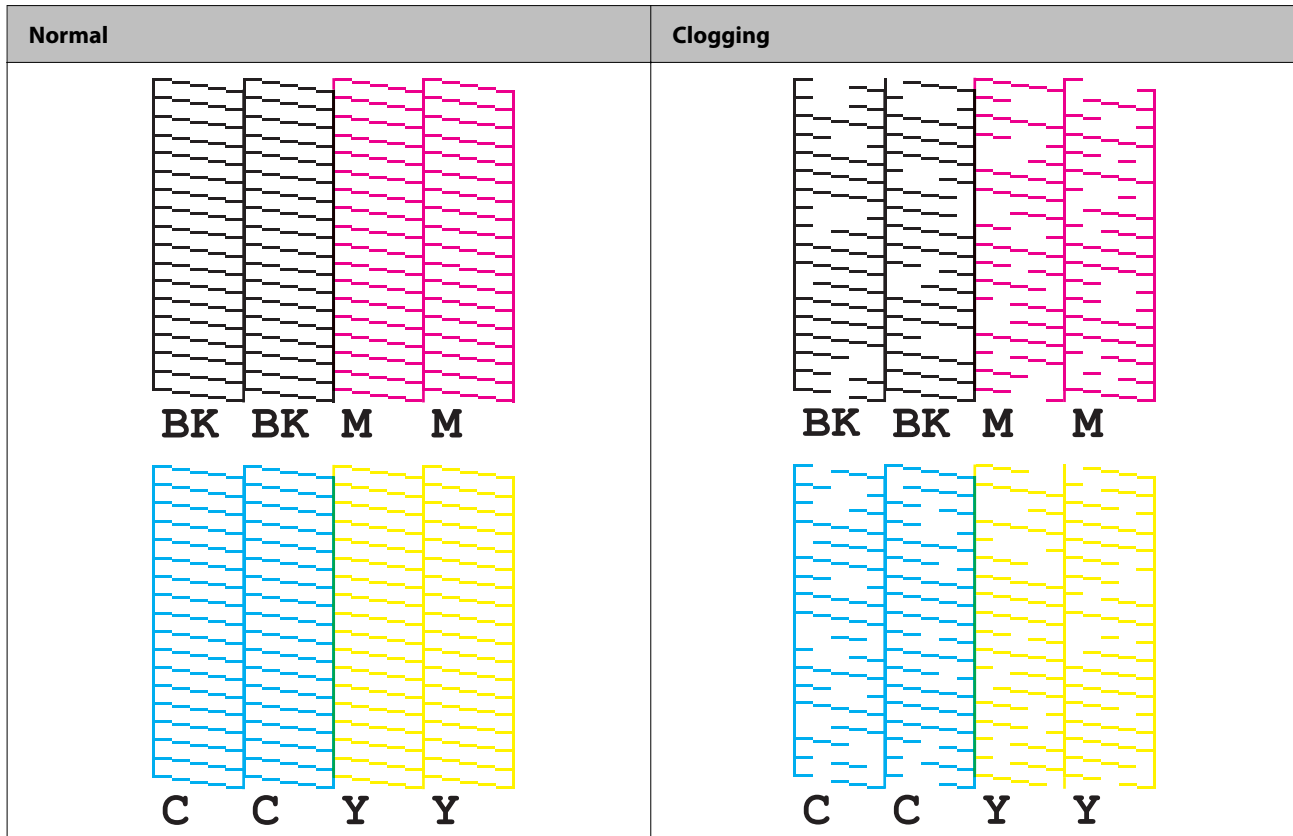

Printing Nozzle Check Patterns

Clogged nozzles cause blurred or streaky printing or printing in unintended colors. If you are experiencing print quality problems, print a nozzle check pattern to see if the nozzles are clogged.

Using the Operation Panel

Menu - Maintenance - Print Head Nozzle Check

Using the Printer Driver

Click **Nozzle Check** on the **Printer Utilities** tab.

Using the Web Config



Select **Print Nozzle Check Pattern** on the **Maintenance** window, and then click **Start**.

<i>Note</i>	For information about Web Config, see the <i>Technical Reference Guide</i> .
-------------	--

Head Cleaning

If nozzles are clogged, run a **Print Head Cleaning**. Run **Power Cleaning** only when nozzle clog is not cleared by running **Print Head Cleaning**.

To run a **Print Head Cleaning**, select the menu as described below.

 Important	<ul style="list-style-type: none"><input type="checkbox"/> The Power Cleaning consumes ink more than Print Head Cleaning.<input type="checkbox"/> Do not turn off the power or open the covers during head cleaning. Doing so may cause printing malfunction.<input type="checkbox"/> Do not run the head cleaning more than necessary. Ink is consumed because ink is discharged from the head to clean it.<input type="checkbox"/> If there is not much ink remaining, head cleaning may not be possible. Replace the ink cartridges and then try again. <p> "Replacing the Ink Cartridges" on page 35</p>
--	--

Using the Operation Panel

Menu - Maintenance - Print Head Cleaning

Menu - Maintenance - Power Cleaning

Using the Printer Driver

Click **Print Head Cleaning** or **Power Cleaning** on the **Printer Utilities** window.

Using the Web Config

Select **Print Head Cleaning** on the **Maintenance** window. Then select the cleaning type from **Auto** or **Power Cleaning**, and then click **Start**.

Note	<p>When logging in to Web Config, you need to enter your user name and password. The initial values are as follows.</p> <p>User name: Blank or a freely selected character string</p> <p>Password: The value for PASSWORD on the label affixed to the rear of the product</p>
-------------	---

Troubleshooting

This chapter describes how to resolve problems. For troubleshooting information that is not described here, see the *Technical Reference Guide*.





A Message is Displayed on the Operation Panel

Message	Solution and Reference
<p>Information</p> <p>Paper feed error.</p> <p>Load the paper or change the media source setting.</p>	<p>Use paper that matches the Media Source and Media Form settings. Or change the Media Source and Media Form settings to match them with the loaded paper.</p> <p> "Printer Driver Settings" on page 41</p>
<p>Information</p> <p>Cannot detect the roll paper.</p> <p>Reload the paper or change the media detection setting.</p>	<p>Use paper that matches the Media Detect settings. Or change the Media Detect settings to match them with the loaded paper.</p> <p> "Printer Driver Settings" on page 41</p>
<p>Information</p> <p>Cannot detect the fanfold paper.</p> <p>Reload the paper or change the media detection setting.</p>	<p>Use paper that matches the Media Detect settings. Or change the Media Detect settings to match them with the loaded paper.</p> <p> "Printer Driver Settings" on page 41</p>
<p>(On the home screen)</p> <p>Load paper.</p>	<p>Load paper.</p> <p> "Loading and Replacing Paper" on page 48</p>
<p>Information</p> <p>The paper size set in the printer may differ from the print setting.</p>	<p>Load media that matches the print area size. Or change the print area to match it with the media size.</p> <p> "Loading and Replacing Paper" on page 48</p>
<p>Information</p> <p>The roll paper is not loaded.</p>	<p>Load roll paper.</p> <p> "Loading and Replacing Paper" on page 48</p>
<p>Information</p> <p>The fanfold paper is not loaded.</p>	<p>Load fanfold paper.</p> <p> "Loading and Replacing Paper" on page 48</p>
<p>Information</p> <p>Paper jam.</p>	<p>Remove the jammed paper and then load paper.</p> <p> "Paper is jammed" on page 94</p>



Troubleshooting

Message	Solution and Reference
<p>Information</p> <p>The paper is not loaded correctly.</p> <p>Remove the paper from the top of the paper guide, close the paper cover, and then press the Pause button.</p>	<p>Remove the paper, and then load the paper again.</p> <p>🔗 “How to Remove Paper (For the Auto Cutter Model)” on page 67</p> <p>🔗 “How to Remove Paper (For the Peeler Model)” on page 69</p> <p>🔗 “Loading and Replacing Paper” on page 48</p> <p>If this error occurs when loading paper</p> <p>Reload the paper following the procedure below.</p> <p>Open the paper cover, remove the paper from the top of the paper guide, close the paper cover, and then press the Pause button.</p> <p>When the home screen appears on the operation panel, open the cover and load paper.</p> <p>🔗 “Loading and Replacing Paper” on page 48</p> <p>If the above step does not clear the error, check the position of the gap detector. For details on how to operate the detectors, refer to the <i>Technical Reference Guide</i>.</p>
<p>Information</p> <p>Calibration failed.</p> <p>Press the OK button. Then reload or replace the paper.</p>	<p>Make sure that the paper loaded in the printer matches the paper detection method (gap or black mark), and reset the paper.</p> <p>🔗 “Loading and Replacing Paper” on page 48</p> <p>If the error still occurs, the detector cannot handle the paper. Replace the paper.</p>
<p>Information</p> <p>The paper has already been cut and cannot be cut.</p>	<p>This error occurs when you press the Cut button at the position where the paper is already cut.</p> <p>Feed the paper by printing or pressing the Feed button to enable the Cut button.</p>
<p>Maintenance Error</p> <p>The ink cartridge is not installed correctly.</p>	<p>Install an ink cartridge with a sufficient amount of ink remaining.</p> <p>🔗 “How to Replace the Ink Cartridges” on page 35</p>
<p>(On the home screen, an exclamation mark on the ink levels)</p>	<p>Prepare a new ink cartridge to be replaced with the low-ink-level cartridge.</p> <p>If you continue to use the low-ink-level cartridge, you may be required to replace it during printing.</p> <p>If you replace the cartridge during printing, you may see a difference in color between colors printed by the old cartridge and colors printed by the new one due to a difference in ink drying status.</p> <p>If it is not acceptable for you, replace the ink cartridge with a new one before starting printing.</p> <p>🔗 “How to Replace the Ink Cartridges” on page 35</p> <p>The removed ink cartridge can be installed again and used until you are prompted to replace it.</p>
<p>Information</p> <p>You need to replace the following ink cartridge(s).</p>	<p>Install an ink cartridge with a sufficient amount of ink remaining.</p> <p>🔗 “How to Replace the Ink Cartridges” on page 35</p>
<p>Maintenance Error</p> <p>Cannot recognize the ink cartridge.</p> <p>Select “Next” to clear the error.</p>	<p>Reinstall the ink cartridge.</p> <p>If the error reoccurs, replace the ink cartridge with a new one.</p> <p>🔗 “How to Replace the Ink Cartridges” on page 35</p>

Troubleshooting



Message	Solution and Reference
<p>Information</p> <p>You have not installed genuine Epson ink cartridges.</p>	<p>For the best performance of the printer, it is recommended to use genuine Epson ink cartridges.</p> <p>Use of non-genuine Epson ink cartridges can adversely affect the printer and print quality and prevent the printer from realizing its maximum performance.</p> <p>Epson cannot guarantee the quality and reliability of non-genuine Epson products.</p> <p>Repairs for any damage or breakdown of this product due to the use of non-genuine Epson products will not be free of charge even if the warranty period is still valid.</p>
<p>Information</p> <p>These ink cartridges are not compatible.</p>	<p>Because the installed ink cartridges are not the ones for this printer, an error such as a cartridge detection error may occur.</p>
<p>Maintenance Error</p> <p>Maintenance Box not installed.</p> <p>Model number: SJMB6000/6500</p>	<p>Install a new maintenance box.</p> <p> "How to Replace the Maintenance Box" on page 38</p>
<p>Maintenance Error</p> <p>Cannot recognize the Maintenance Box.</p> <p>Model number: SJMB6000/6500</p>	<p>Reinstall the maintenance box.</p> <p>If the error still occurs, replace the maintenance box with a new one.</p> <p> "How to Replace the Maintenance Box" on page 38</p>
<p>(On the home screen)</p> <p>The Maintenance Box is nearing end of its service life.</p>	<p>Prepare a new maintenance box to be replaced with the near-full maintenance box.</p> <p>When a message saying "The Maintenance Box is at the end of its service life. You need to replace it." is displayed, replace the maintenance box.</p> <p> "How to Replace the Maintenance Box" on page 38</p>
<p>Maintenance Error</p> <p>The Maintenance Box is at the end of its service life.</p> <p>You need to replace it.</p> <p>Model number: SJMB6000/6500</p>	<p>Replace the maintenance box with a new one.</p> <p> "How to Replace the Maintenance Box" on page 38</p>
<p>Information</p> <p>Memory Full. Document was not printed.</p>	<p>Delete unnecessary files.</p>
<p>Printer Error</p> <p>Turn on the printer again.</p> <p>See your documentation for more details.</p> <p>XXXXXX</p>	<ol style="list-style-type: none"> 1. Turn off the printer. 2. Check that there is no paper jam or foreign materials near the ejection slot. 3. Turn the printer on. <p>If the printer error still occurs, contact qualified service personnel for advice. When contacting, tell the person the "XXXXXXX" (a 6- or 8-digit alphanumeric code).</p>
<p>Information</p> <p>Cannot start cleaning because ink is low.</p> <p>Printer features except cleaning are available.</p>	<p>When running the cleaning, install ink cartridges with a sufficient amount of ink remaining.</p> <p> "How to Replace the Ink Cartridges" on page 35</p>
<p>Information</p> <p>Remove the label.</p>	<p>Remove the labels from the peeler.</p> <p>If the error is not cleared, press the Peeler Reset button.</p>

Troubleshooting

Message	Solution and Reference
<p>Information</p> <p>Paused</p> <p>The print quality may decrease because the nozzles are clogged.</p>	<p>The print quality may decrease because the nozzles are clogged. If it is not acceptable, run a print head cleaning.</p> <p> "Cleaning the Print Head" on page 84</p>
<p>Information</p> <p>Open the front cover, and then close the paper holder unit.</p>	<p>Open the front cover, and then close the paper holder unit. When the paper holder unit is opened, a paper jam error may occur. If the paper jam error is not cleared, try the solutions in the links below.</p> <p>Auto cutter model:</p> <p> "For the Auto Cutter Model" on page 94</p> <p>Peeler model:</p> <p> "For the Peeler Model" on page 97</p>
<p>The printer can't connect to cloud service.</p> <p>Please check the connection status and settings with the cloud service.</p> <p>Please contact your administrator for details.</p>	<p>The printer is failing to connect to the Loftware Cloud.</p> <p>Contact your system administrator for more information.</p>

Problems with Print Quality



Horizontal White Banding

Cause	Solution and Reference
The nozzles are clogging.	<p>Print the nozzle check patterns to check the nozzles for clogging.</p> <p> "Printing Nozzle Check Patterns" on page 84</p> <p>If the nozzles are clogging, run a print head cleaning.</p> <p> "Cleaning the Print Head" on page 84</p>

Vertical White Spots (Auto Cutter Model)

Cause	Solution and Reference
The printed label has been back-fed.	<p>If printed labels are fed backward, the printed surface is damaged by the rollers located under the paper pressure unit.</p> <p>This can occur when the print mode is set to Stop at Cut Position or Stop at Peel-Off Position, and printed labels have not been removed after each print job is finished.</p> <p>Select a print mode option other than Stop at Cut Position or Stop at Peel-Off Position, or remove printed labels after each print job is finished.</p> <p>For details on the print modes, refer to the <i>Technical Reference Guide</i>.</p>



White or Black Banding

Cause	Solution and Reference
The paper is not loaded correctly.	<p>Reload the paper.</p> <p> "Loading and Replacing Paper" on page 48</p>
The paper being used and the Media Coating Type setting differ.	<p>Check the paper being used and the Media Coating Type setting of the printer driver.</p> <p> "Printer Driver Settings" on page 41</p>



Printed Colors Are Wrong

Cause	Solution and Reference
If the printer is moved after initial charging, the specified colors may not be output (colors may be mixed) due to vibrations and impacts.	<p>Run a head cleaning and check that colors are no longer mixed.</p> <p> "Cleaning the Print Head" on page 84</p>

Print Position Shifts

Cause	Solution and Reference
The edge guide is not set along the paper edge.	Check that the edge guide is properly set at the paper width position.  "Loading and Replacing Paper" on page 48
The paper you are using is set at an angle. (Peeler model)	Make sure that the edge of the paper is aligned with the protrusion below the peeler cover.  "Loading and Replacing Paper" on page 48

Paper is Smearred or Smudged with Ink

Cause	Solution and Reference
The paper being used and the Media Coating Type setting differ.	Check the paper being used and the Media Coating Type setting of the printer driver.  "Printer Driver Settings" on page 41
If foreign matter is adhered to the head, the paper may be smeared with ink.	Run a print head cleaning.  "Cleaning the Print Head" on page 84

Paper is Fed and Ejected, and an Error Occurs

Cause	Solution and Reference
The paper being used differs from that of Media detection settings.	Check the paper being used and Media detection settings of the printer.  "Printer Driver Settings" on page 41

Printing is Impossible or Becomes Suddenly Impossible

Print Data is Sent, But Does Not Print (Peeler Model)

Cause	Solution and Reference
The label peeling detector is malfunctioning.	If printing is performed at a location exposed to strong light such as direct sun rays, etc., the label peeling detector may not work properly, making it impossible to perform printing. Press the Peeler Reset button to cancel the non-printing state.

Printing from a computer is impossible or becomes suddenly impossible

Checking Whether the Printer Driver Is Installed

Check whether or not the required software and applications are installed on the computer.

To print with this printer, a printer driver is required. Check whether or not the printer driver is installed by following the steps below.

- 1 Display Devices and Printers on the computer.
- 2 Check that the printer name is displayed.
If not, the printer driver is not installed.
- 3 Install the printer driver.
 [“Downloading the Latest Version” on page 4](#)

The printer does not turn on

Check that the power cable is connected to the printer and outlet properly.

 [“Rear” on page 25](#)

Print Job is Canceled on PC but “Printing” Message on Printer Does Not Disappear

If you cancel printing in printer queue on the computer, it may cause the print data to break up and “Printing” may be kept displayed on the operation panel of the printer.

Troubleshooting

To cancel the status, press the **Cancel** button on the operation panel, and then select **All label formats**.

Paper is jammed

This section describes how to resolve the problem when the paper is jammed. This section is also explained with the help of a video. You can see the video from the link below.

- ❑ CW-C6000/C6500 Series:

[<https://support.epson.net/p_doc/790/>](https://support.epson.net/p_doc/790/)

- ❑ CW-D6000/D6500 Series:

[<https://support.epson.net/p_doc/ab6/>](https://support.epson.net/p_doc/ab6/)

For the Auto Cutter Model

- 1 Cut the paper near the paper ejection slot.

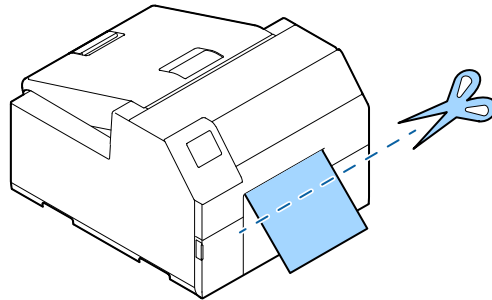

- 2 Open the front cover.

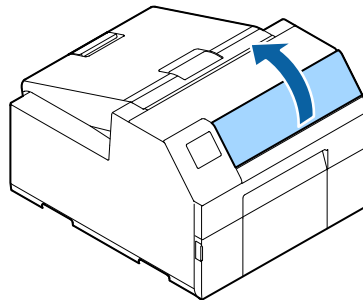

- 3 If there are ripped pieces of paper on the platen, remove them.

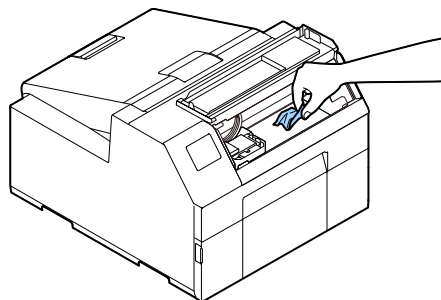

Troubleshooting

- 4** If the print head is not on the far right, hold it down and move it to the far right.
If there is jammed paper, remove it.

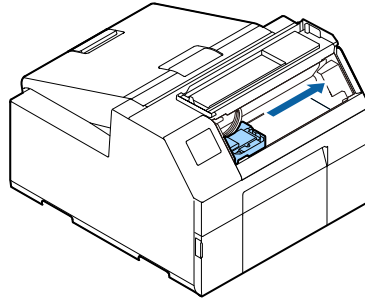

- 5** Open the paper cover.

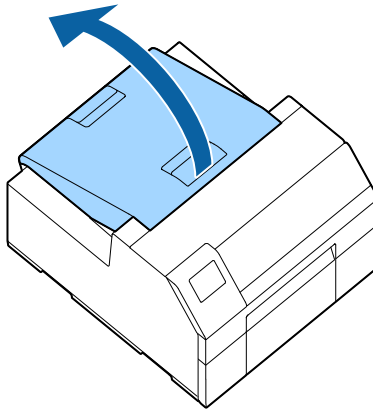

- 6** Raise the release lever.

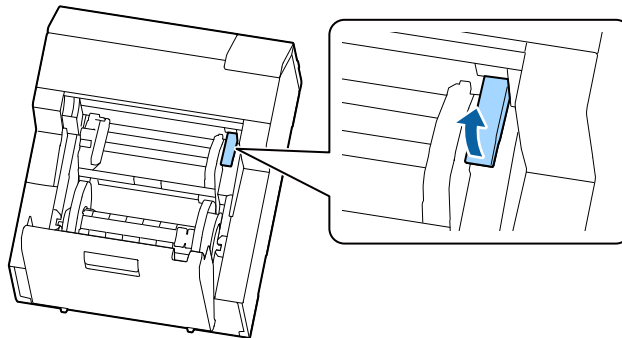

Troubleshooting

- 7 Pull the paper out from the paper feed slot.

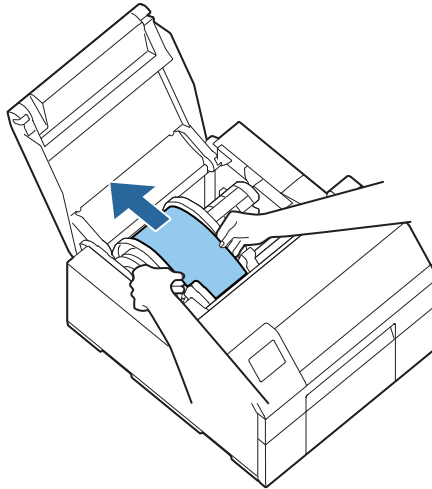

- 8 Lower the release lever.

- 9 Close the paper cover.

- 10 Close the front cover.

- 11 Press the **Pause** button.

The paper jam error will be cleared.

To resume printing, load the paper again.

 [“How to Load Paper \(Auto Cutter Model - Supply from Inside\)” on page 50](#)

 [“How to Load Paper \(Auto Cutter Model - Supply from Outside\)” on page 55](#)

If the problem of paper jam cannot be resolved even after following the steps above, refer to the *Technical Reference Guide*.

Note	After removing jammed paper, make sure that there is no labels or adhesive left inside the printer. If you use the printer without removing them, it leads to frequent paper jams, or may cause poor print quality. If paper jam occurs frequently, clean the inside of the printer.  “Maintenance” on page 73
-------------	---

For the Peeler Model

- 1 Open the peeler cover.

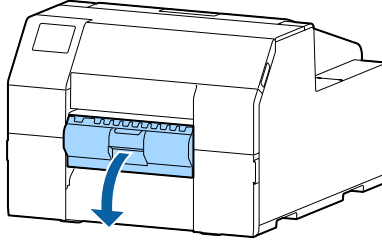

- 2 Cut the paper near the paper ejection slot.

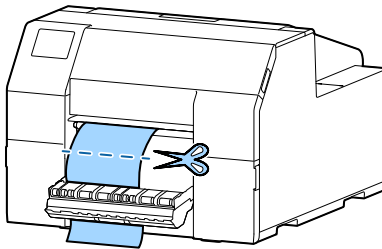

- 3 Open the front cover.

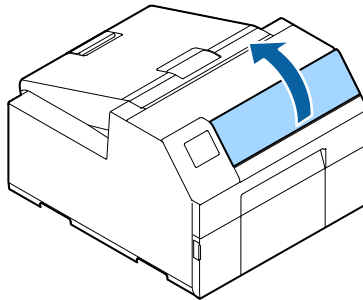

- 4 If there are ripped pieces of paper on the platen, remove them.

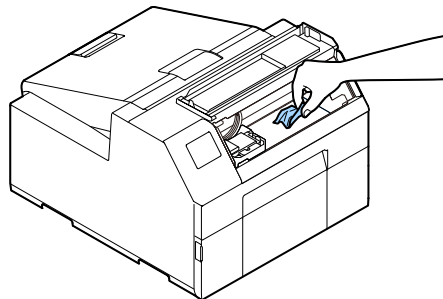

Troubleshooting

- 5** If the print head is not on the far right, hold it down and move it to the far right.
If there is jammed paper, remove it.

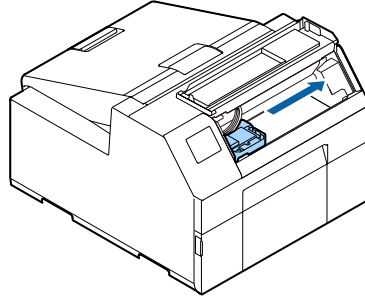

- 6** Open the paper cover.

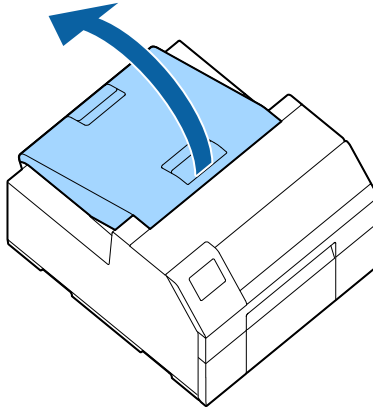

- 7** Raise the release lever.

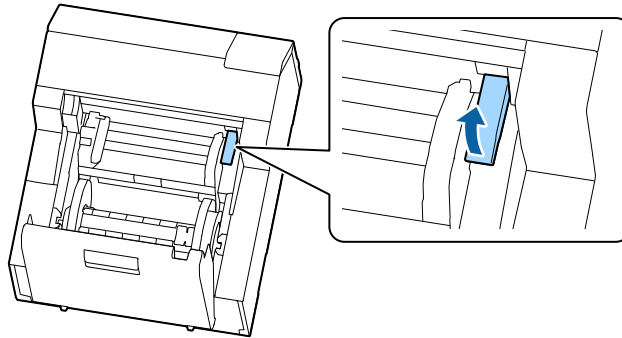

Troubleshooting

- 8** Pull the paper out from the paper feed slot.

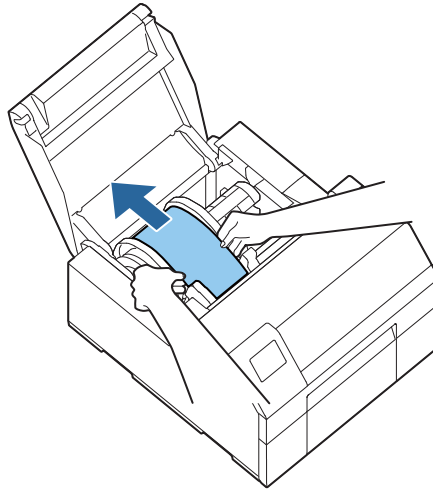

- 9** Lower the release lever.

- 10** Close the paper cover.

- 11** Close the front cover.

- 12** Close the peeler cover.

- 13** Press the **Pause** button.

The paper jam error will be cleared.

To resume printing, load the paper again.

 [“How to Load Paper \(Peeler Model - Supply from Inside\)” on page 60](#)

If the problem of paper jam cannot be resolved even after following the steps above, refer to the *Technical Reference Guide*.

Note

After removing jammed paper, make sure that there is no labels or adhesive left inside the printer. If you use the printer without removing them, it leads to frequent paper jams, or may cause poor print quality. If paper jam occurs frequently, clean the inside of the printer.

 [“Maintenance” on page 73](#)

Specifications

This chapter describes the specifications of the printer.

CW-C6000 Series

Product Specifications

Item		Specifications	
Printing method		Serial inkjet, dot matrix method Four-color printing	
Paper feed method		Forward and reverse friction feed	
Cutting type of the auto cutter (Auto cutter model only)		Full cut (cuts paper completely)	
Print resolution		300 × 600 dpi 600 × 600 dpi 600 × 1200 dpi 1200 × 1200 dpi	
Print speed	Print quality setting: Max Speed 300 × 600 dpi (width × height)	Printing width: 25.4 mm {1.00 in.}	156 mm/s {6.14 in/s}
		Printing width: 101.6 mm {4.00 in.}	119 mm/s {4.69 in/s}
		Printing width: 203.2 mm {8.00 in.}	-
	Print quality setting: Speed 600 × 600 dpi (width × height)	Printing width: 25.4 mm {1.00 in.}	125 mm/s {4.92 in/s}
		Printing width: 101.6 mm {4.00 in.}	75 mm/s {2.95 in/s}
		Printing width: 203.2 mm {8.00 in.}	-
	Print quality setting: Normal 600 × 600 dpi (width × height)	Printing width: 25.4 mm {1.00 in.}	63 mm/s {2.48 in/s}
		Printing width: 101.6 mm {4.00 in.}	48 mm/s {1.89 in/s}
		Printing width: 203.2 mm {8.00 in.}	-
	Print quality setting: Quality 600 × 1200 dpi (width × height)	Printing width: 25.4 mm {1.00 in.}	27 mm/s {1.06 in/s}
		Printing width: 101.6 mm {4.00 in.}	18 mm/s {0.71 in/s}
		Printing width: 203.2 mm {8.00 in.}	-
Print quality setting: Max Quality 1200 × 1200 dpi (width × height)	Printing width: 25.4 mm {1.00 in.}	11 mm/s {0.43 in/s}	
	Printing width: 101.6 mm {4.00 in.}	8 mm/s {0.31 in/s}	
	Printing width: 203.2 mm {8.00 in.}	-	

Specifications

Item		Specifications
Interface	Wired LAN*	1000BASE-T/100BASE-TX /10BASE-T
	USB	USB2.0 High-Speed
	External input/output interface	D-sub25
Weight	Auto cutter model	Approx. 22.5 kg {49.6 lb}
	Peeler model	Approx. 22.8 kg {50.26 lb}

*Use a shielded twisted-pair cable.

Electrical Specifications

Item		Specifications	
Power supply		Power supply through a power connector	
Rated voltage		100 to 240 V	
Frequency		50 to 60 Hz	
Rated current		0.9 A	
Power consumption	Operating	100 V	Approx. 39.4 W on average
		230 V	Approx. 38.6 W on average
	Standby	100 V	Approx. 7.51 W on average
		230 V	Approx. 5.82 W on average
	Power off	100 V	Approx. 0.08 W on average
		230 V	Approx. 0.24 W on average

Overall Dimensions

Item	Specifications
Height	326 mm {12.83 in.}
Width	340 mm {13.39 in.}
Depth	565 mm {22.24 in.}*

* Excludes the protrusion

Specifications

CW-C6500 Series

Product Specifications

Item		Specifications	
Printing method		Serial inkjet, dot matrix method Four-color printing	
Paper feed method		Forward and reverse friction feed	
Cutting type of the auto cutter (Auto cutter model only)		Full cut (cuts paper completely)	
Print resolution		300 × 600 dpi 600 × 600 dpi 600 × 1200 dpi 1200 × 1200 dpi	
Print speed	Print quality setting: Max Speed 300 × 600 dpi (width × height)	Printing width: 25.4 mm {1.00 in.}	156 mm/s {6.14 in/s}
		Printing width: 101.6 mm {4.00 in.}	119 mm/s {4.69 in/s}
		Printing width: 203.2 mm {8.00 in.}	85 mm/s {3.35 in/s}
	Print quality setting: Speed 600 × 600 dpi (width × height)	Printing width: 25.4 mm {1.00 in.}	125 mm/s {4.92 in/s}
		Printing width: 101.6 mm {4.00 in.}	75 mm/s {2.95 in/s}
		Printing width: 203.2 mm {8.00 in.}	49 mm/s {1.93 in/s}
	Print quality setting: Normal 600 × 600 dpi (width × height)	Printing width: 25.4 mm {1.00 in.}	63 mm/s {2.48 in/s}
		Printing width: 101.6 mm {4.00 in.}	48 mm/s {1.89 in/s}
		Printing width: 203.2 mm {8.00 in.}	34 mm/s {1.34 in/s}
	Print quality setting: Quality 600 × 1200 dpi (width × height)	Printing width: 25.4 mm {1.00 in.}	27 mm/s {1.06 in/s}
		Printing width: 101.6 mm {4.00 in.}	18 mm/s {0.71 in/s}
		Printing width: 203.2 mm {8.00 in.}	13 mm/s {0.51 in/s}
Print quality setting: Max Quality 1200 × 1200 dpi (width × height)	Printing width: 25.4 mm {1.00 in.}	11 mm/s {0.43 in/s}	
	Printing width: 101.6 mm {4.00 in.}	8 mm/s {0.31 in/s}	
	Printing width: 203.2 mm {8.00 in.}	6 mm/s {0.24 in/s}	
Interface		Wired LAN*	1000BASE-T/100BASE-TX /10BASE-T
		USB	USB2.0 High-Speed
		External input/output interface	D-sub25
Weight	Auto cutter model	Approx. 25.5 kg {49.6 lb}	
	Peeler model	Approx. 26.3 kg {57.98 lb}	

Specifications

*Use a shielded twisted-pair cable.

Electrical Specifications

Item		Specifications	
Power supply		Power supply through a power connector	
Rated voltage		100 to 240 V	
Frequency		50 to 60 Hz	
Rated current		0.9 A	
Power consumption	Operating	100 V	Approx. 39.5 W on average
		230 V	Approx. 38.7 W on average
	Standby	100 V	Approx. 7.51 W on average
		230 V	Approx. 5.82 W on average
	Power off	100 V	Approx. 0.08 W on average
		230 V	Approx. 0.24 W on average

Overall Dimensions

Item	Specifications
Height	326 mm {12.83 in.}
Width	444 mm {17.48 in.}
Depth	515 mm {20.28 in.} *

* Excludes the protrusion

Specifications

CW-D6000 Series

Product Specifications

Item		Specifications	
Printing method		Serial inkjet, dot matrix method Four-color printing	
Paper feed method		Forward and reverse friction feed	
Cutting type of the auto cutter (Auto cutter model only)		Full cut (cuts paper completely)	
Print resolution		300 × 600 dpi (only for matte and synthetic paper) 600 × 600 dpi 600 × 1200 dpi 1200 × 1200 dpi (only for Glossy Paper, Glossy Film, and High Glossy Paper)	
Print speed	Print quality setting: Max Speed 300 × 600 dpi (width × height)	Printing width: 25.4 mm {1.00 in.}	156 mm/s {6.14 in/s}
		Printing width: 101.6 mm {4.00 in.}	119 mm/s {4.69 in/s}
		Printing width: 203.2 mm {8.00 in.}	-
	Print quality setting: Speed 600 × 600 dpi (width × height)	Printing width: 25.4 mm {1.00 in.}	125 mm/s {4.92 in/s}
		Printing width: 101.6 mm {4.00 in.}	75 mm/s {2.95 in/s}
		Printing width: 203.2 mm {8.00 in.}	-
	Print quality setting: Normal 600 × 600 dpi (width × height)	Printing width: 25.4 mm {1.00 in.}	63 mm/s {2.48 in/s}
		Printing width: 101.6 mm {4.00 in.}	48 mm/s {1.89 in/s}
		Printing width: 203.2 mm {8.00 in.}	-
	Print quality setting: Quality 600 × 1200 dpi (width × height)	Printing width: 25.4 mm {1.00 in.}	27 mm/s {1.06 in/s}
		Printing width: 101.6 mm {4.00 in.}	18 mm/s {0.71 in/s}
		Printing width: 203.2 mm {8.00 in.}	-
Print quality setting: Max Quality 1200 × 1200 dpi (width × height)	Printing width: 25.4 mm {1.00 in.}	11 mm/s {0.43 in/s}	
	Printing width: 101.6 mm {4.00 in.}	8 mm/s {0.31 in/s}	
	Printing width: 203.2 mm {8.00 in.}	-	
Interface		Wired LAN*	1000BASE-T/100BASE-TX /10BASE-T
		USB	USB2.0 High-Speed
		External input/output interface	D-sub25
Weight	Auto cutter model		Approx. 22.5 kg {49.6 lb}
	Peeler model		Approx. 22.8 kg {50.26 lb}

Specifications

*Use a shielded twisted-pair cable.

Electrical Specifications

Item		Specifications	
Power supply		Power supply through a power connector	
Rated voltage		100 to 240 V	
Frequency		50 to 60 Hz	
Rated current		0.9 A	
Power consumption	Operating	100 V	Approx. 39.4 W on average
		230 V	Approx. 38.6 W on average
	Standby	100 V	Approx. 7.51 W on average
		230 V	Approx. 5.82 W on average
	Power off	100 V	Approx. 0.08 W on average
		230 V	Approx. 0.24 W on average

Overall Dimensions

Item	Specifications
Height	326 mm {12.83 in.}
Width	340 mm {13.39 in.}
Depth	565 mm {22.24 in.} *

* Excludes the protrusion

Specifications

CW-D6500 Series

Product Specifications

Item		Specifications	
Printing method		Serial inkjet, dot matrix method Four-color printing	
Paper feed method		Forward and reverse friction feed	
Cutting type of the auto cutter (Auto cutter model only)		Full cut (cuts paper completely)	
Print resolution		300 × 600 dpi (only for matte and synthetic paper) 600 × 600 dpi 600 × 1200 dpi 1200 × 1200 dpi (only for Glossy Paper, Glossy Film, and High Glossy Paper)	
Print speed	Print quality setting: Max Speed 300 × 600 dpi (width × height)	Printing width: 25.4 mm {1.00 in.}	156 mm/s {6.14 in/s}
		Printing width: 101.6 mm {4.00 in.}	119 mm/s {4.69 in/s}
		Printing width: 203.2 mm {8.00 in.}	85 mm/s {3.35 in/s}
	Print quality setting: Speed 600 × 600 dpi (width × height)	Printing width: 25.4 mm {1.00 in.}	125 mm/s {4.92 in/s}
		Printing width: 101.6 mm {4.00 in.}	75 mm/s {2.95 in/s}
		Printing width: 203.2 mm {8.00 in.}	49 mm/s {1.93 in/s}
	Print quality setting: Normal 600 × 600 dpi (width × height)	Printing width: 25.4 mm {1.00 in.}	63 mm/s {2.48 in/s}
		Printing width: 101.6 mm {4.00 in.}	48 mm/s {1.89 in/s}
		Printing width: 203.2 mm {8.00 in.}	34 mm/s {1.34 in/s}
	Print quality setting: Quality 600 × 1200 dpi (width × height)	Printing width: 25.4 mm {1.00 in.}	27 mm/s {1.06 in/s}
		Printing width: 101.6 mm {4.00 in.}	18 mm/s {0.71 in/s}
		Printing width: 203.2 mm {8.00 in.}	13 mm/s {0.51 in/s}
Print quality setting: Max Quality 1200 × 1200 dpi (width × height)	Printing width: 25.4 mm {1.00 in.}	11 mm/s {0.43 in/s}	
	Printing width: 101.6 mm {4.00 in.}	8 mm/s {0.31 in/s}	
	Printing width: 203.2 mm {8.00 in.}	6 mm/s {0.24 in/s}	
Interface		Wired LAN*	1000BASE-T/100BASE-TX /10BASE-T
		USB	USB2.0 High-Speed
		External input/output interface	D-sub25
Weight	Auto cutter model	Approx. 25.5kg {49.6 lb}	
	Peeler model	Approx. 26.3kg {57.98 lb}	

Specifications

*Use a shielded twisted-pair cable.

Electrical Specifications

Item		Specifications	
Power supply		Power supply through a power connector	
Rated voltage		100 to 240 V	
Frequency		50 to 60 Hz	
Rated current		0.9 A	
Power consumption	Operating	100 V	Approx. 39.5 W on average
		230 V	Approx. 38.7 W on average
	Standby	100 V	Approx. 7.51 W on average
		230 V	Approx. 5.82 W on average
	Power off	100 V	Approx. 0.08 W on average
		230 V	Approx. 0.24 W on average

Overall Dimensions

Item	Specifications
Height	326 mm {12.83 in.}
Width	444 mm {17.48 in.}
Depth	515 mm {20.28 in.} *

* Excludes the protrusion

Specifications

Environmental Specifications

Temperature /humidity	Printing	5 to 35°C {41 to 95°F}, 20 to 80% RH without condensation (the blue-colored range in the graph)		
	Barcode printing	15 to 35°C {59 to 95°F}, 20 to 80% RH without condensation		
	Storage (CW-C6000/ C6500 Series)	When packed (Ink not charged)	-20 to 60°C {-4 to 140°F}, 5 to 85% RH without condensation (Within 120 hours at -20°C {-4°F} or 60°C {140°F})	
		With ink charged	Gloss black ink	-15 to 40°C {5 to 104°F}, 20 to 85% RH without condensation (Within 120 hours at -15°C {5°F}) (Within 6 months at 0 to 25°C {32 to 77°F}) (Within 1 month at 40°C {104°F})
		Matte black ink	-10 to 40°C {14 to 104°F}, 20 to 85% RH without condensation (Within 120 hours at -10°C {14°F}) (Within 6 months at 0 to 25°C {32 to 77°F}) (Within 1 month at 40°C {104°F}) Can be stored at -20°C {-4°F} with ink discharged	
Storage (CW-D6000/ D6500 Series)	When packed (Ink not charged)	-20 to 60°C {-4 to 140°F}, 5 to 85% RH without condensation (Within 120 hours at -20°C {-4°F} or 60°C {140°F})		
	With ink charged	-10 to 40°C {14 to 104°F}, 20 to 85% RH without condensation (Within 120 hours at -10°C {14°F}) (Within 6 months at 0 to 25°C {32 to 77°F}) (Within 1 month at 40°C {104°F})		
Elevation	3000 m or less			
Noise	Auto cutter model: Approx. 55 dB Peeler model: Approx. 60 dB Based on Epson evaluation conditions.			

Paper Specifications

The following types of paper can be used with the printer.

CW-C6000/C6500 Series

When using Gloss black ink

- Matte Paper
- Synthetic
- Glossy Paper
- Glossy Film
- High Glossy Paper

When using Matte black ink

- Plain Paper
- Matte Paper
- Synthetic
- Texture Paper

CW-D6000/D6500 Series

- Matte Paper
- Synthetic
- Glossy Paper
- Glossy Film
- High Glossy Paper

Specifications

Ink Cartridge

Model number	CW-C6000Au, CW-C6000Pu, CW-C6500Au, CW-C6500Pu	SJIC35P-BK, SJIC35P-MK, SJIC35P-C, SJIC35P-M, SJIC35P-Y
	CW-C6000Ae, CW-C6000Pe, CW-C6500Ae, CW-C6500Pe	SJIC36P-BK, SJIC36P-MK, SJIC36P-C, SJIC36P-M, SJIC36P-Y
	CW-C6010A, CW-C6010P, CW-C6510A, CW-C6510P	SJIC36P-BK, SJIC36P-MK, SJIC36P-C, SJIC36P-M, SJIC36P-Y
	CW-C6020A, CW-C6020P, CW-C6520A, CW-C6520P	SJIC37P-BK, SJIC37P-MK, SJIC37P-C, SJIC37P-M, SJIC37P-Y
	CW-C6030A, CW-C6030P, CW-C6530A, CW-C6530P	SJIC38P-BK, SJIC38P-MK, SJIC38P-C, SJIC38P-M, SJIC38P-Y
	CW-C6040A, CW-C6040P, CW-C6540A, CW-C6540P	SJIC39P-BK, SJIC39P-MK, SJIC39P-C, SJIC39P-M, SJIC39P-Y
	CW-C6050A, CW-C6050P, CW-C6550A, CW-C6550P	SJIC40P-BK, SJIC40P-MK, SJIC40P-C, SJIC40P-M, SJIC40P-Y
	CW-D6000Ae, CW-D6000Pe, CW-D6500Ae, CW-D6500Pe	SJIC55P-BK, SJIC55P-C, SJIC55P-M, SJIC55P-Y
Type		4 individual color cartridges
Ink colors	CW-C6000/C6500 Series	Black (gloss black (BK), matte black (MK)), cyan (C), magenta (M), yellow (Y)
	CW-D6000/D6500 Series	Black (BK), cyan (C), magenta (M), yellow (Y)
Ink type	CW-C6000/C6500 Series	Pigment ink
	CW-D6000/D6500 Series	Dye ink
Expiration date		6 months after installation in the printer, 3 years after manufacture including the period of use
Storage temperature	Transporting (without unpacking)	-20 to 60°C {-4 to 140°F} (within 4 days at -20°C {-4°F}, within 1 month at 40°C {104°F}, within 5 days at 60°C {140°F})
	Storage (without unpacking)	-20 to 40°C {-4 to 104°F} (within 4 days at -20°C {-4°F}, within 1 month at 40°C {104°F})
	Installed	-20 to 40°C {-4 to 104°F} (within 4 days at -20°C {-4°F}, within 1 month at 40°C {104°F})

Specifications

Maintenance Box

Model number	SJMB6000/6500	
Type	Maintenance box with integrated waste ink absorbing material	
Storage temperature	Transporting (without unpacking)	-20 to 60°C {-4 to 140°F} (within 5 days at 60°C {140°F})
	Storage (without unpacking)	-20 to 40°C {-4 to 104°F} (within 1 month at 40°C {104°F})
	Installed	-20 to 40°C {-4 to 104°F} (within 1 month at 40°C {104°F})

Appendix

Consumables and Options

Consumables and options for this product are available. They can be purchased from sales representatives.

Ink Cartridge

Four ink cartridge colors are used. Black ink can be selected from gloss black and matte black. *

For the ink cartridges that can be used with this product, refer to [“Ink Cartridge” on page 110](#).

Replace the ink cartridge(s) when you are prompted to do so.

 [“Replacing the Ink Cartridges” on page 35](#)

* Some models of the printer cannot use matte black ink.

Genuine Ink Cartridges Recommended

- For the best performance of the printer, it is recommended to use genuine Epson ink cartridges. Use of non-genuine Epson ink cartridges can adversely affect the printer and print quality and prevent the printer from realizing its maximum performance. Epson cannot guarantee the quality and reliability of non-genuine Epson products. Repairs for any damage or breakdown of this product due to the use of non-genuine Epson products will not be free of charge even if the warranty period is still valid.
- Color adjustment of the product is based on the use of genuine Epson ink cartridges. Use of non-genuine ink cartridges may result in reduced print quality. Epson recommends the use of genuine Epson ink cartridges.

Disposal of Ink Cartridges

Dispose the ink cartridges properly following the law or regulations of your country and area.

Maintenance Box

The maintenance box is a box used to collect waste ink. The maintenance box available for this product is:

Model number: SJMB6000/6500

Replace the maintenance box when you are prompted to do so.

 [“Replacing the Maintenance Box” on page 38](#)

Genuine Maintenance Box Recommended

For the best performance of the printer, it is recommended to use a genuine Epson maintenance box. Use of a non-genuine Epson maintenance box can adversely affect the printer and prevent the printer from realizing its maximum performance. Repairs for any damage or breakdown of this product due to the use of non-genuine Epson products will not be free of charge even if the warranty period is still valid. Epson cannot guarantee the quality and reliability of non-genuine Epson products.

Disposal of Maintenance Box

Dispose the ink maintenance box properly following the law or regulations of your country and area.

Roll Paper Holder

A spare roll paper holder is provided as an option. In the following cases, replacement of the roll paper can be performed quickly by loading paper beforehand in the spare roll paper holder.

- When you want to use paper of a different size or frequently change the label material
- When you want to reduce the down time as a result of roll paper replacement

Model number:

- Paper Holder C6000 (for CW-C6000/D6000 Series)
- Paper Holder C6500 (for CW-C6500/D6500 Series)

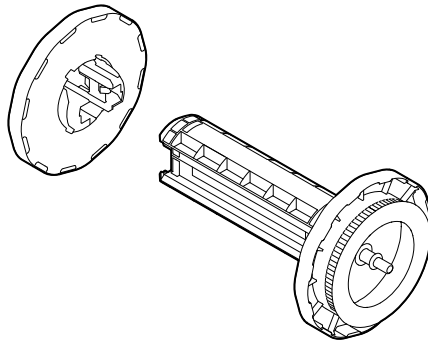

Item	Paper Holder C6000	Paper Holder C6500
External dimensions (H × W × D)	220 × 206 × 220 mm {8.66 × 8.11 × 8.66 in.}	175 × 310 × 175 mm {6.89 × 12.20 × 6.89 in.}
Weight	0.65 kg {1.43 lb}	0.65 kg {1.43 lb}

Restriction of Use

When this product is used for applications requiring high reliability/safety such as transportation devices related to aviation, rail, marine, automotive etc.; disaster prevention devices; various safety devices etc.; or functional/precision devices etc., you should use this product only after giving consideration to including fail-safes and redundancies into your design to maintain safety and total system reliability. This product is not intended for use in applications requiring an extremely high level of reliability and safety, such as in aerospace instruments, main communication equipment, nuclear power control equipment, or medical equipment, etc. Please make your own judgment on this product's suitability after a full evaluation.

Notes

- (1) All rights reserved. No part of this publication may be reproduced, stored in a retrieval system, or transmitted in any form or by any means, electronic, mechanical, photocopying, recording, or otherwise, without the prior written permission of Seiko Epson Corporation.
- (2) The content of this manual is subject to change without notice.
- (3) While every precaution has been taken in the preparation of this manual, Seiko Epson Corporation assumes no responsibility for errors or omissions.
- (4) Neither is any liability assumed for damages resulting from the use of the information contained herein.
- (5) Neither Seiko Epson Corporation nor its affiliates shall be liable to the purchaser of this product or third parties for damages, losses, costs, or expenses incurred by purchaser or third parties as a result of: accident, misuse, or abuse of this product or unauthorized modifications, repairs, or alterations to this product, or (excluding the U.S.) failure to strictly comply with Seiko Epson Corporation's operating and maintenance instructions.
- (6) Seiko Epson Corporation shall not be liable for any damages or problems arising from the use of any options or any consumable products other than those designated as Genuine Epson Products or Epson Approved Products by Seiko Epson Corporation.

Trademarks

Microsoft, Windows are trademarks of the Microsoft group of companies.

All other trademarks are the property of their respective owners and used for identification purpose only.

©Seiko Epson Corporation 2019–2025